



# Drum / Wing Quotation Sheet

Company Name \_\_\_\_\_ Date \_\_\_\_\_

Attention \_\_\_\_\_ City \_\_\_\_\_

Phone # \_\_\_\_\_ Fax # \_\_\_\_\_

## Quotation

Please check appropriate boxes and indicate your specifications:

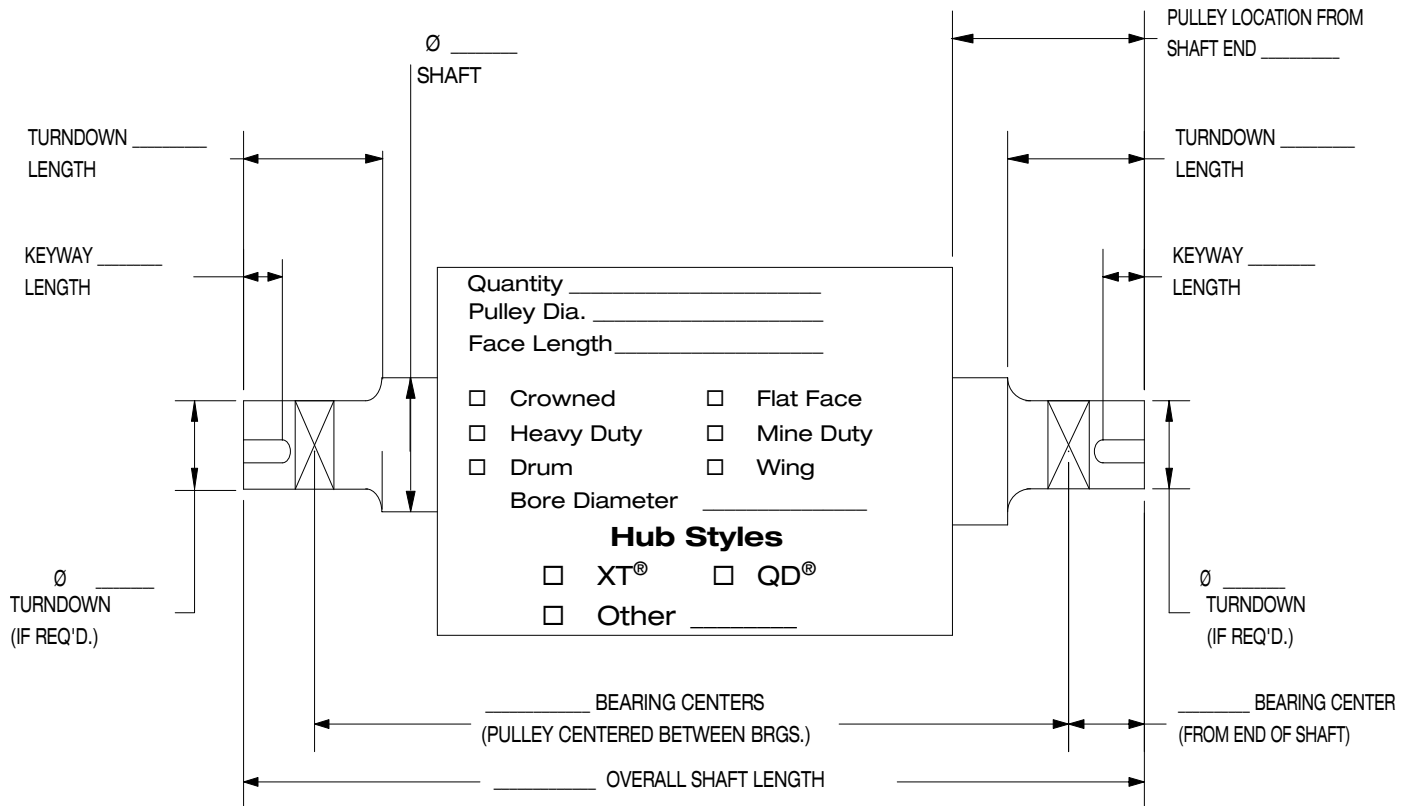

### Lagging Options

#### Compounds

- SBR
- EPDM
- Neoprene
- Carboxylated Nitrile
- Other \_\_\_\_\_

Thickness \_\_\_\_\_

Durometer \_\_\_\_\_

#### Grooves

- Herringbone
- Diamond
- Chevron
- Other \_\_\_\_\_

Special Requirements \_\_\_\_\_

\_\_\_\_\_

Unless otherwise stated - All prices are F.O.B. ALPENA, MICH. and firm for 30 days. Terms of payment are NET 30 DAYS subject to credit approval. Quoted delivery is based on current inventory status and/or material availability: check delivery when placing order. Stenographic and clerical errors are subject to correction. Title to all goods passes to the buyer at the shipping point.

<p><b>PRO CAL INC.</b> Toll Free: 800-323-0966</p>	<p>3810 U.S. 23 North • P.O. Box 115 • Alpena, MI 49707-0115 Direct Dial Pulley Assistance: (989) 358-6149 • Phone: (989) 358-7070 Fax: (989) 358-7075 • www.pcimfg.com</p>
--	---