

PCI

**PNEUMATIC
CLUTCHES - BRAKES - CLUTCH/BRAKES**



*Seal of
Excellence*

PCI is committed to manufacturing a quality product to meet your demanding standards. Each unit is inspected numerous times during the manufacturing process, assuring you of quality second to none. Every unit is then individually packaged and sealed with the **PCI Seal of Excellence**.

TABLE OF CONTENTS

CLUTCHES	Series	Page
Ball Bearing Pilot Models		
Thru Shaft Mount - Single Drive	CS	1
End of Shaft Mount - Single Drive	CR	2
Thru Shaft Mount - Multiple Drive	CM	3
End of Shaft Mount - Multiple Drive	CE	4
Bronze Bushing Pilot Models		
Thru Shaft Mount - Single Drive	CU	5
End of Shaft Mount - Single Drive	CY	6
CLUTCH/BRAKES		
Hub Start/Stop - Ball Bearing Pilot Models		
Thru Shaft Mount - Single Drive	XH	7
End of Shaft Mount - Single Drive	XE	8
Thru Shaft Mount - Multiple Drive	XM	9
End of Shaft Mount - Multiple Drive	XB	10
Drive Start/Stop - Ball Bearing Pilot Models		
Thru Shaft Mount - Single Drive	XP	11
End of Shaft Mount - Single Drive	XQ	12
Thru Shaft Mount - Multiple Drive	XT	13
End of Shaft Mount - Multiple Drive	XJ	14
BRAKES		
Air Set Models		
Thru Shaft Mount - Back Mounted	BK	15
Thru Shaft Mount - Flange Mounted	BF	16
TORQUE LIMITERS		
Bronze Bushing Pilot Models		
Thru Shaft Mount - Single Drive	TL	17
MODULAR COMPONENTS		
In-Line Models		
Coupler	MC	18
Clutch Housing	MH	18
Clutch Mechanism	MP	19
Torque Limiter Mechanism	MF	20
ENGINEERING DATA		
Application Information		21
<ul style="list-style-type: none"> • Torque Ratings/Wear-In • Selection Guides • Installation Instructions 	<ul style="list-style-type: none"> • "TL" Adjustment Instructions • Safety Factors • General Notes 	<ul style="list-style-type: none"> • Rotary Union Options • Rebuild Kits • Specials

MADE IN THE U.S.A.



This catalog is made from recycled paper.



“CS” Series - Clutch

Ball Bearing Pilot - Thru Shaft Mount - Single Drive

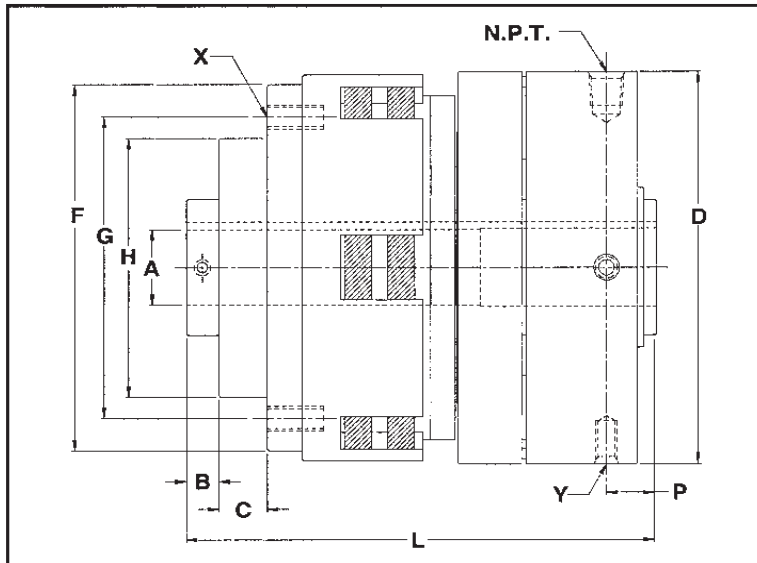

Available with a sprocket or V-Belt sheave.

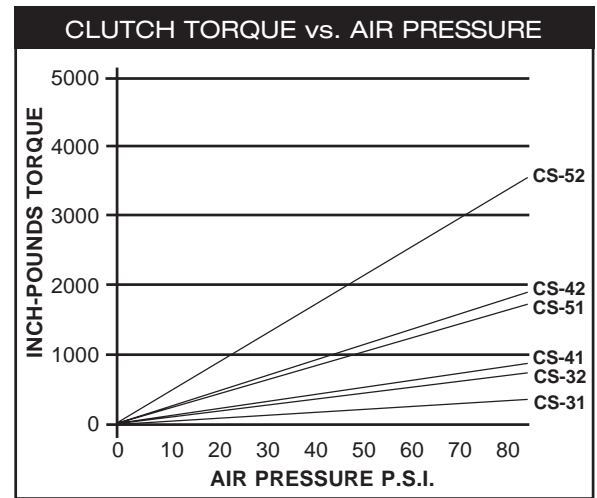

MODEL	A-BORE $\begin{smallmatrix} +.002 \\ -.000 \end{smallmatrix}$	B	C	D	F	G	H $\begin{smallmatrix} +.000 \\ -.002 \end{smallmatrix}$	X	Y	N.P.T.	L	P
CS - 31	5/8 - 3/4	.28	.25	3.48	2.75	2.43	2.12	[4] 10-32	1/4-20	1/8	3.51	.45
CS - 32	5/8 - 7/8	.37	.50	3.48	3.48	3.00	2.50	[4] 1/4-20	1/4-20	1/8	4.30	.45
CS - 41	3/4 - 1 1/8	.38	.56	4.56	4.25	3.50	3.00	[4] 1/4-20	1/4-20	1/8	4.82	.62
CS - 42	3/4 - 1 1/8	.38	.56	4.56	4.25	3.50	3.00	[4] 1/4-20	1/4-20	1/8	5.32	.62
CS - 51	1 - 1 7/16	.50	.75	5.73	5.50	4.75	4.00	[4] 5/16-18	1/4-20	1/8	5.52	.69
CS - 52	1 - 1 7/16	.50	.75	5.73	5.50	4.75	4.00	[4] 5/16-18	1/4-20	1/8	6.02	.69

HOW TO ORDER

Example: **CS - 32 - 14**

Model Bore Size in 1/16"
(14 = 14/16" or 7/8" Bore)

Contact PCI for part numbers on units that include a sprocket or V-Belt sheave.

SINGLE - TYPE 'A' SPROCKET SIZES (using standard single strand roller chain)							
PILOT DIAMETER	SPROCKET NUMBER						
	25	35	40-41	50	60	80	100
H	MINIMUM # OF TEETH						
2.12	39	27	21	---	---	---	---
2.50	48	33	26	21	18	---	---
3.00	58	40	31	25	22	---	---
4.00	74	50	38	32	27	21	18

See Engineering Data (page 21) for Selection Guide, Installation Instructions and other application information.



“CR” Series - Clutch

Ball Bearing Pilot - End of Shaft Mount - Single Drive

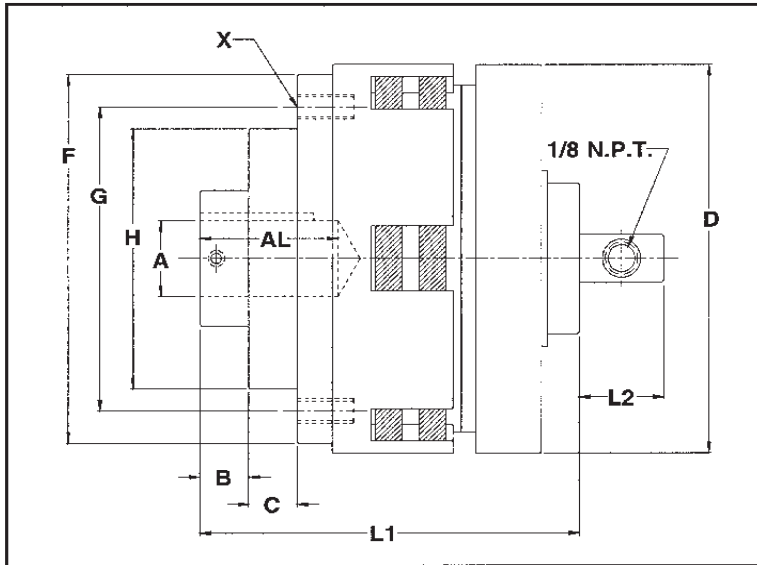

Available with a sprocket or V-Belt sheave.

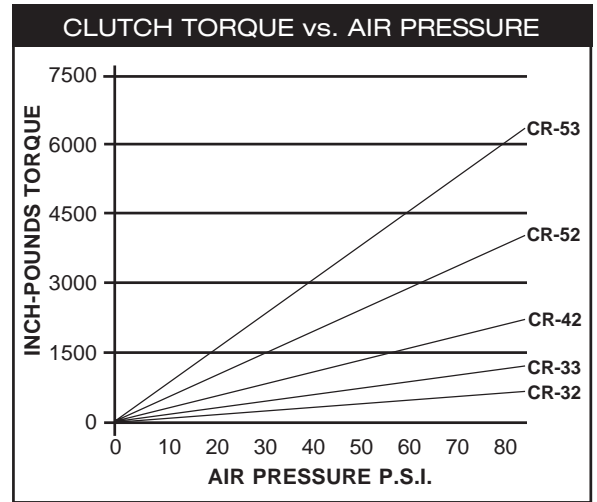

MODEL	A-BORE $\begin{smallmatrix} +.002 \\ -.000 \end{smallmatrix}$	AL	B	C	D	F	G	H $\begin{smallmatrix} +.000 \\ -.002 \end{smallmatrix}$	X	L1	L2
CR - 32	5/8 - 7/8	1.75	.38	.50	3.48	3.48	3.00	2.50	[4] 1/4-20	3.66	.77
CR - 33	5/8 - 7/8	2.00	.38	.50	3.48	3.48	3.00	2.50	[4] 1/4-20	4.00	.77
CR - 42	3/4 - 1 1/8	2.00	.56	.56	4.48	4.25	3.50	3.00	[4] 1/4-20	4.38	.77
CR - 52	1 - 1 7/16	2.50	.50	.75	5.63	5.50	4.75	4.00	[4] 5/16-18	4.87	.77
CR - 53	1 - 1 7/16	2.75	.50	.75	5.63	5.50	4.75	4.00	[4] 5/16-18	5.37	.77

HOW TO ORDER

Example: **CR - 33 - 14**

/ /

Model Bore Size in 1/16"
(14 = 14/16" or 7/8" Bore)

Contact PCI for part numbers on units that include a sprocket or V-Belt sheave.

SINGLE - TYPE 'A' SPROCKET SIZES (using standard single strand roller chain)							
PILOT DIAMETER	SPROCKET NUMBER						
	25	35	40-41	50	60	80	100
H	MINIMUM # OF TEETH						
2.50	48	33	26	21	18	---	---
3.00	58	40	31	25	22	---	---
4.00	74	50	38	32	27	21	18

See Engineering Data (page 21) for Selection Guide, Installation Instructions and other application information.



“CM” Series - Clutch

Ball Bearing Pilot - Thru Shaft Mount - Multiple Drive

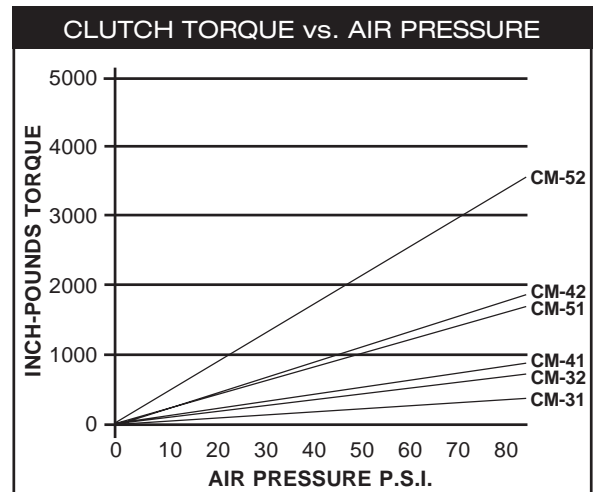
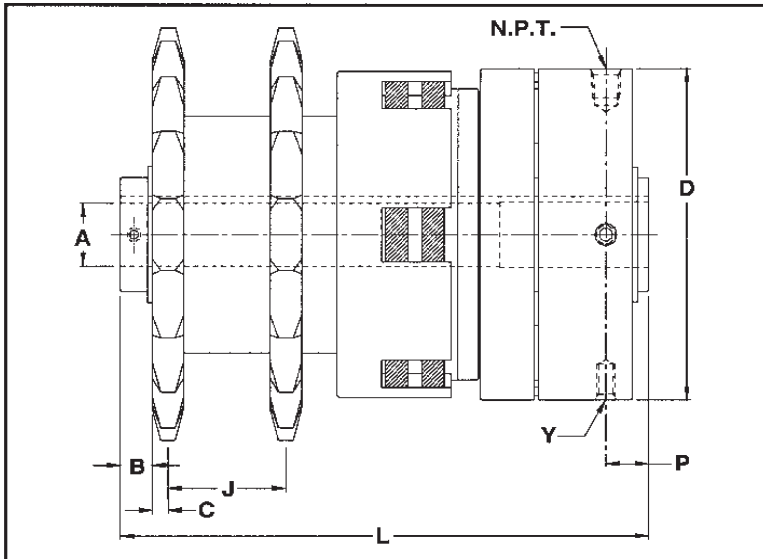

Supplied with sprockets or V-Belt sheaves.

MODEL	A-BORE $\begin{smallmatrix} +.002 \\ -.000 \end{smallmatrix}$	B	C	D	J	Y	N.P.T.	L	P
CM - 31	5/8 - 7/8	.38	*	3.48	*	1/4-20	1/8	*	.45
CM - 32	5/8 - 7/8	.38	*	3.48	*	1/4-20	1/8	*	.45
CM - 41	3/4 - 1 1/8	.44	*	4.56	*	1/4-20	1/8	*	.62
CM - 42	3/4 - 1 1/8	.44	*	4.56	*	1/4-20	1/8	*	.62
CM - 51	1 - 1 7/16	.50	*	5.73	*	1/4-20	1/8	*	.69
CM - 52	1 - 1 7/16	.50	*	5.73	*	1/4-20	1/8	*	.69

* Dimension varies depending on sprocket size - see chart below.

* VARIABLE DIMENSIONS								
DIMENSION	SPROCKET NUMBER							
	25	35	41	40	50	60	80	100
C	.04	.07	.10	.13	.16	.22	.27	.33
J	1.00	1.00	1.13	1.13	1.13	1.25	1.63	2.00
L	NOTE: Dimension varies depending on model and sprocket combination. (See pg. 21)							

SINGLE - TYPE 'A' SPROCKET SIZES (using standard single strand roller chain)							
MODEL	SPROCKET NUMBER						
	25	35	40-41	50	60	80	100
MINIMUM # OF TEETH							
CM - 31	45	31	24	20	17	---	---
CM - 32	45	31	24	20	17	---	---
CM - 41	45	31	24	20	17	---	---
CM - 42	45	31	24	20	17	---	---
CM - 51	55	37	29	24	21	16	14
CM - 52	55	37	29	24	21	16	14

HOW TO ORDER

Example: **CM - 32 - 14**

/ /

Model Bore Size in 1/16"
(14 = 14/16" or 7/8" Bore)

Contact PCI for part numbers on units that include sprockets or V-Belt sheaves.

See Engineering Data (page 21) for Selection Guide, Installation Instructions, Dual Sprocket O.A.L. Dimension Chart and other application information.



“CE” Series - Clutch

Ball Bearing Pilot - End of Shaft Mount - Multiple Drive

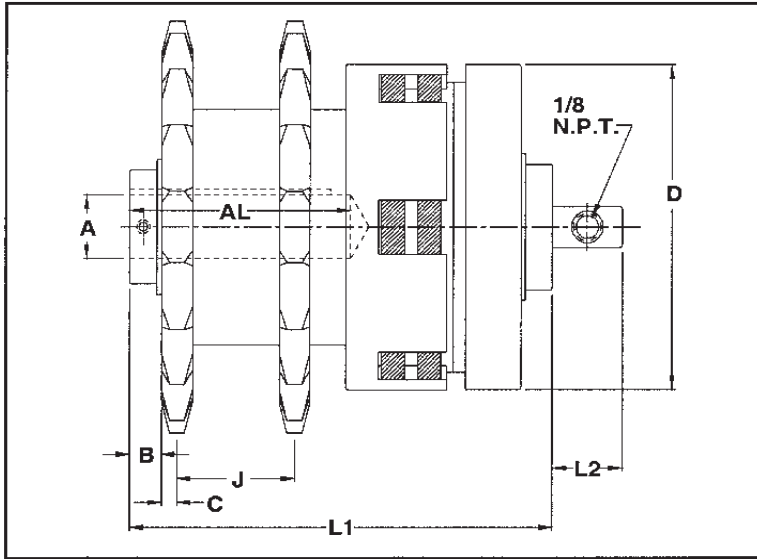

Supplied with sprockets or V-Belt sheaves.

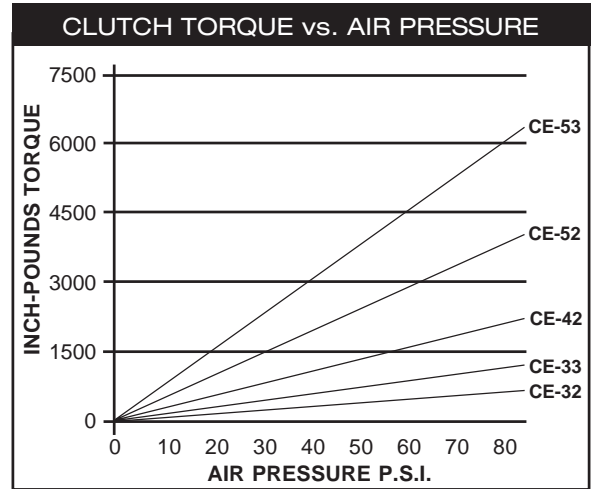

MODEL	A-BORE $\pm \frac{.002}{.000}$	AL	B	C	D	J	L1	L2
CE - 32	5/8 - 1	2.00	.38	*	3.48	*	*	.77
CE - 33	5/8 - 1	2.25	.38	*	3.48	*	*	.77
CE - 42	3/4 - 1 1/8	2.00	.44	*	4.48	*	*	.77
CE - 52	1 - 1 7/16	2.50	.50	*	5.63	*	*	.77
CE - 53	1 - 1 7/16	2.75	.50	*	5.63	*	*	.77

* Dimension varies depending on sprocket size - see chart below.

* VARIABLE DIMENSIONS								
DIMENSION	SPROCKET NUMBER							
	25	35	41	40	50	60	80	100
C	.04	.07	.10	.13	.16	.22	.27	.33
J	1.00	1.00	1.13	1.13	1.13	1.25	1.63	2.00
L1	NOTE: Dimension varies depending on model and sprocket combination. (See pg. 21)							

SINGLE - TYPE 'A' SPROCKET SIZES (using standard single strand roller chain)							
MODEL	SPROCKET NUMBER						
	25	35	40-41	50	60	80	100
MINIMUM # OF TEETH							
CE - 32	45	31	24	20	17	---	---
CE - 33	45	31	24	20	17	---	---
CE - 42	45	31	24	20	17	---	---
CE - 52	55	37	29	24	21	16	14
CE - 53	55	37	29	24	21	16	14

HOW TO ORDER

Example: **CE - 42 - 14**

Model Bore Size in 1/16"
(14 = 14/16" or 7/8" Bore)

Contact PCI for part numbers on units that include sprockets or V-Belt sheaves.

See Engineering Data (page 21) for Selection Guide, Installation Instructions, Dual Sprocket O.A.L. Dimension Chart and other application information.



"CU" Series - Clutch

Bronze Bushing Pilot - Thru Shaft Mount - Single Drive

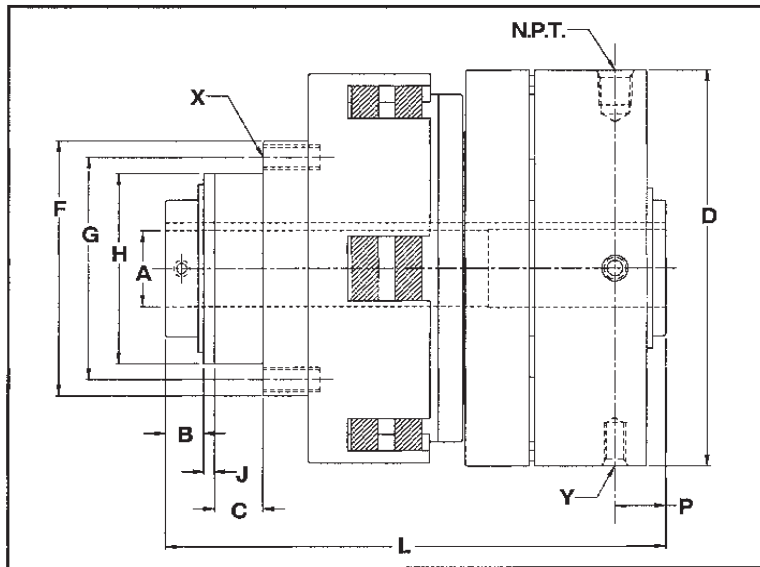

Available with a sprocket or V-Belt sheave.

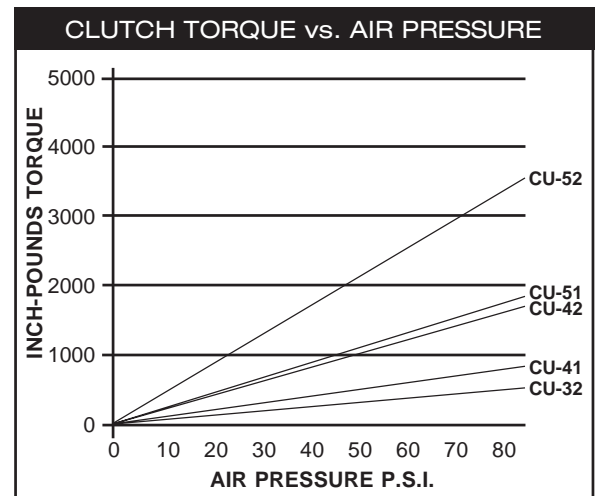

MODEL	A-BORE ^{+.002} / _{-.000}	B	C	D	F	G	H ^{+.000} / _{-.002}	J	X	Y	N.P.T.	L	P
CU - 32	5/8 - 1	.44	.43	3.48	2.63	2.31	2.00	.13	[3] 10-32	1/4-20	1/8	4.63	.52
CU - 41	3/4 - 1 1/4	.44	.56	4.56	2.94	2.56	2.19	.13	[6] 10-32	1/4-20	1/8	5.27	.65
CU - 42	3/4 - 1 1/4	.44	.56	4.56	2.94	2.56	2.19	.13	[6] 10-32	1/4-20	1/8	5.77	.65
CU - 51	1 - 1 7/16	.49	.63	5.73	3.75	3.12	2.75	.13	[6] 1/4-20	1/4-20	1/8	5.81	.70
CU - 52	1 - 1 7/16	.49	.63	5.73	3.75	3.12	2.75	.13	[6] 1/4-20	1/4-20	1/8	6.31	.70

SINGLE - TYPE 'A' SPROCKET SIZES (using standard single strand roller chain)							
PILOT DIAMETER	SPROCKET NUMBER						
	25	35	40-41	50	60	80	100
H	MINIMUM # OF TEETH						
2.00	38	26	20	17	---	---	---
2.19	41	29	22	19	16	---	---
2.75	52	36	27	23	20	16	---

HOW TO ORDER

Example: **CU - 32 - 14**

Model **Bore Size in 1/16"**
 (14 = 14/16" or 7/8" Bore)

Contact PCI for part numbers on units that include a sprocket or V-Belt sheave.

See Engineering Data (page 21) for Selection Guide, Installation Instructions and other application information.



“CY” Series - Clutch

Bronze Bushing Pilot - End of Shaft Mount - Single Drive

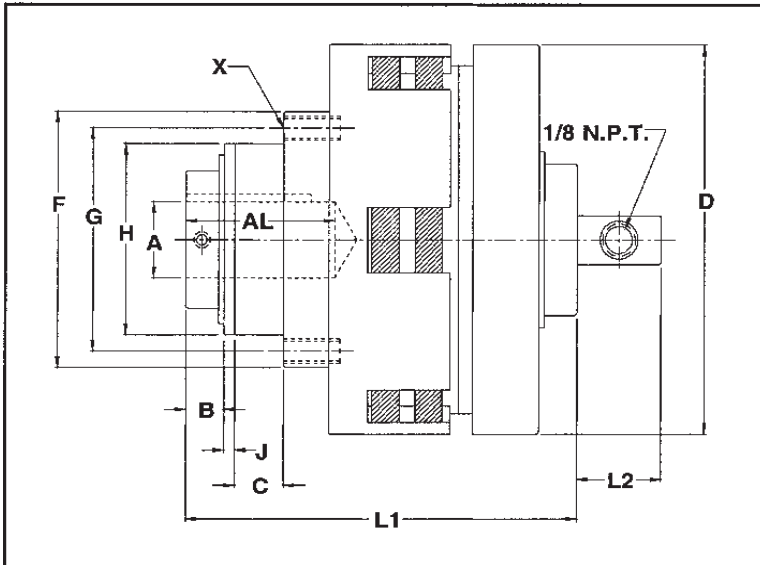

Available with a sprocket or V-Belt sheave.

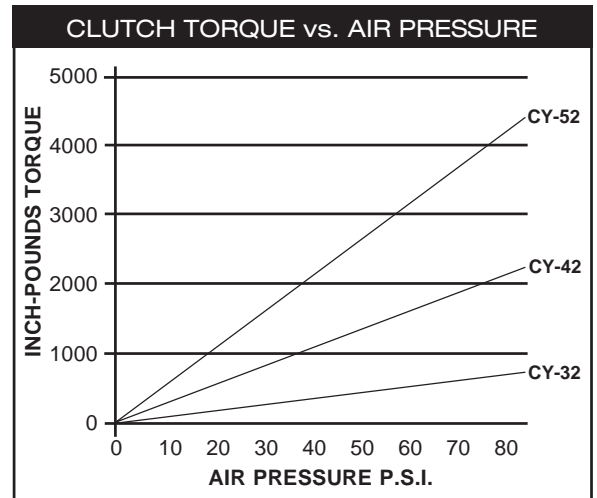

MODEL	A-BORE $\pm .002$ $\pm .000$	AL	B	C	D	F	G	H $\pm .000$ $\pm .002$	J	X	L1	L2
CY - 32	5/8 - 1	1.75	.44	.43	3.48	2.63	2.31	2.00	.13	[3] 10-32	3.67	.77
CY - 42	3/4 - 1 1/4	2.00	.46	.56	4.48	2.94	2.56	2.19	.13	[6] 10-32	4.39	.77
CY - 52	1 - 1 7/16	2.50	.49	.63	5.63	3.75	3.12	2.75	.13	[6] 1/4-20	5.06	.77

HOW TO ORDER

Example: **CY - 42 - 14**

/ /

Model Bore Size in 1/16"
(14 = 14/16" or 7/8" Bore)

Contact PCI for part numbers on units that include a sprocket or V-Belt sheave.

SINGLE - TYPE 'A' SPROCKET SIZES (using standard single strand roller chain)							
PILOT DIAMETER	SPROCKET NUMBER						
	25	35	40-41	50	60	80	100
H	MINIMUM # OF TEETH						
2.00	38	26	20	17	---	---	---
2.19	41	29	22	19	16	---	---
2.75	52	36	27	23	20	16	---

See Engineering Data (page 21) for Selection Guide, Installation Instructions and other application information.



“XH” Series - Clutch/Brake

Hub Start/Stop - Thru Shaft Mount - Single Drive

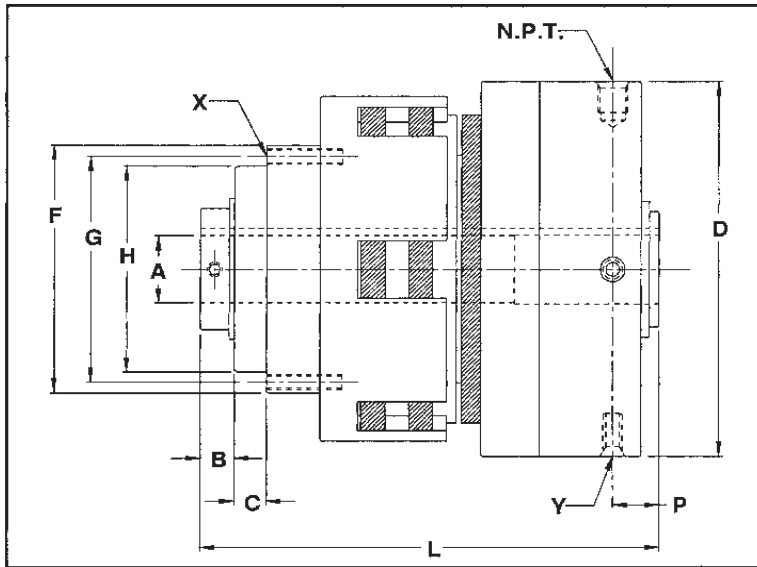

Available with a sprocket or V-belt sheave.

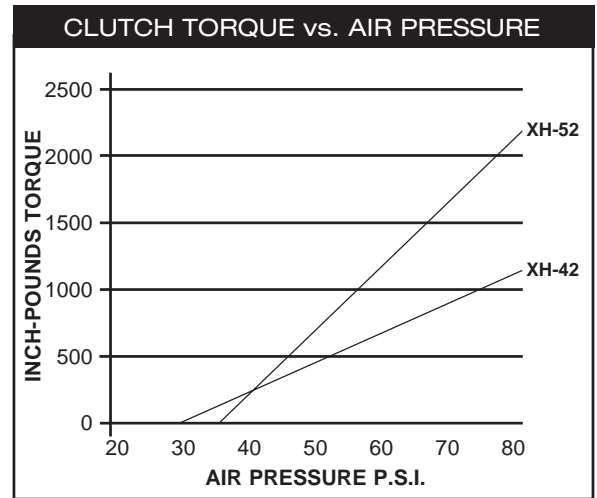

MODEL	A-BORE $^{+.002}_{-.000}$	B	C	D	F	G	H $^{+.000}_{-.002}$	X	Y	N.P.T.	L	P
XH - 42	3/4 - 1	.44	.34	4.88	3.23	2.95	2.677	[6] 10-32	1/4-20	1/8	6.12	.63
XH - 52	1 - 1 1/4	.50	.46	5.88	3.98	3.50	3.150	[3] 1/4-20	5/16-18	1/8	6.34	.67

SPRING SET BRAKE TORQUE	
MODEL	IN. - LBS.
XH - 42	150
XH - 52	375

HOW TO ORDER

Example: **XH - 42 - 14**

Model **Bore Size in 1/16"**
 (14 = 14/16" or 7/8" Bore)

Contact PCI for part numbers on units that include a sprocket or V-Belt sheave.

SINGLE - TYPE 'A' SPROCKET SIZES (using standard single strand roller chain)							
PILOT DIAMETER	SPROCKET NUMBER						
	25	35	40-41	50	60	80	100
H	MINIMUM # OF TEETH						
2.677	---	31	24	20	17	---	---
3.150	---	37	29	24	21	16	---

See Engineering Data (page 21) for Selection Guide, Installation Instructions and other application information.



“XE” Series - Clutch/Brake

Hub Start/Stop - End of Shaft Mount - Single Drive

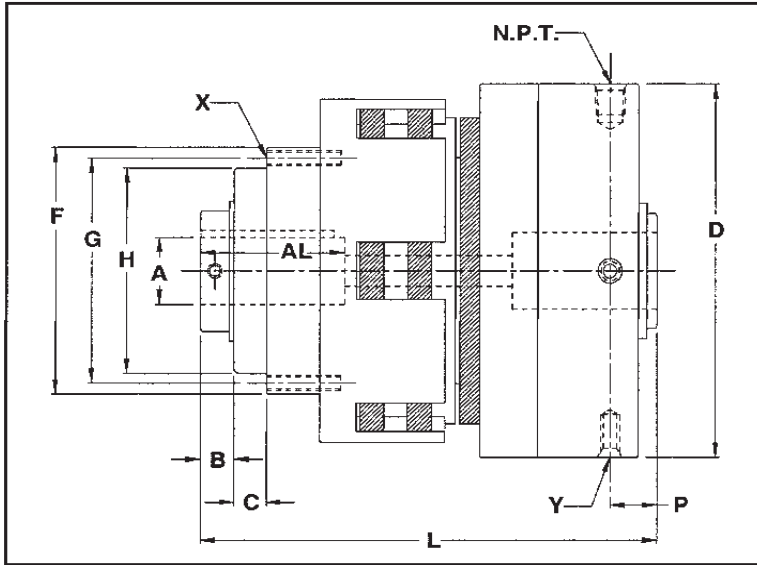

Available with a sprocket or V-belt sheave.

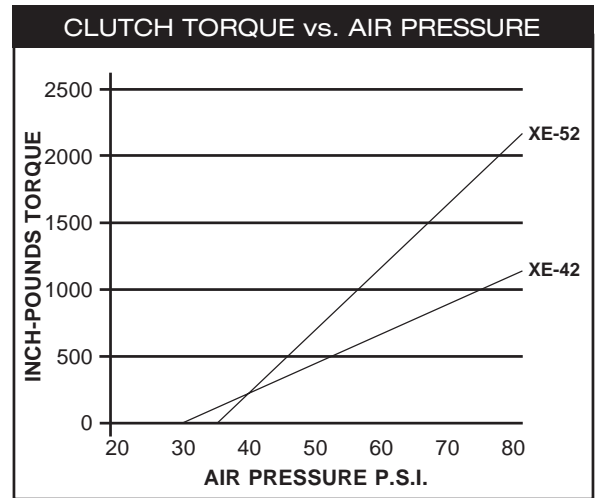

MODEL	A-BORE $\begin{smallmatrix} +.002 \\ -.000 \end{smallmatrix}$	AL	B	C	D	F	G	H $\begin{smallmatrix} +.000 \\ -.002 \end{smallmatrix}$	X	Y	L	P
XE - 42	3/4 - 1	2.25	.44	.34	4.88	3.23	2.95	2.677	[6] 10-32	1/4-20	6.12	.63
XE - 52	1 - 1 7/16	2.50	.50	.46	5.88	3.98	3.50	3.150	[3] 1/4-20	5/16-18	6.34	.67

SPRING SET BRAKE TORQUE	
MODEL	IN. - LBS.
XE - 42	150
XE - 52	375

HOW TO ORDER

Example: **XE - 42 - 14**

Model Bore Size in 1/16"
 (14 = 14/16" or 7/8" Bore)

Contact PCI for part numbers on units that include a sprocket or V-Belt sheave.

SINGLE - TYPE 'A' SPROCKET SIZES (using standard single strand roller chain)							
PILOT DIAMETER	SPROCKET NUMBER						
	25	35	40-41	50	60	80	100
H	MINIMUM # OF TEETH						
2.677	---	31	24	20	17	---	---
3.150	---	37	29	24	21	16	---

See Engineering Data (page 21) for Selection Guide, Installation Instructions and other application information.



“XM” Series - Clutch/Brake

Hub Start/Stop - Thru Shaft Mount - Multiple Drive

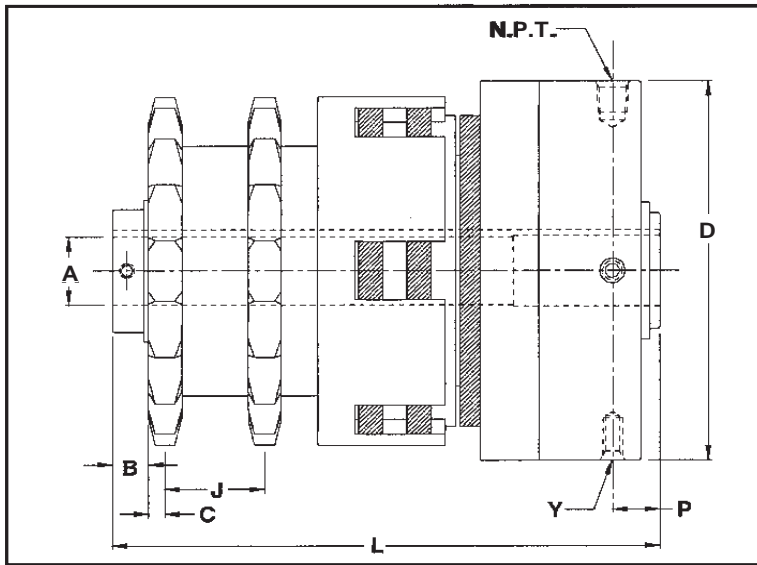

Supplied with sprockets or V-belt sheaves.

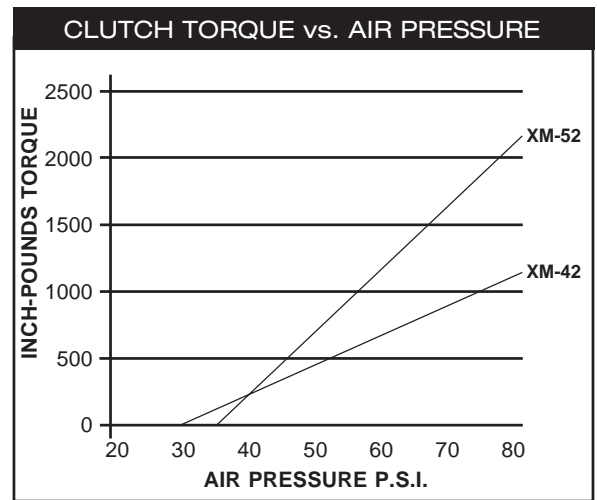

MODEL	A-BORE $\begin{smallmatrix} +.002 \\ -.000 \end{smallmatrix}$	B	C	D	J	Y	N.P.T.	L	P
XM - 42	3/4 - 1	.44	*	4.88	*	1/4-20	1/8	*	.63
XM - 52	1 - 1 1/4	.50	*	5.88	*	5/16-18	1/8	*	.67

* Dimension varies depending on sprocket size - see chart below.

* VARIABLE DIMENSIONS								
DIMENSION	SPROCKET NUMBER							
	25	35	41	40	50	60	80	100
C	.04	.07	.10	.13	.16	.22	.27	.33
J	1.00	1.00	1.13	1.13	1.13	1.25	1.63	2.00
L	NOTE: Dimension varies depending on model and sprocket combination. (See pg. 21)							

SPRING SET BRAKE TORQUE	
MODEL	IN. - LBS.
XM - 42	150
XM - 52	375

HOW TO ORDER

Example: **XM - 42 - 14**

Model Bore Size in 1/16"
 (14 = 14/16" or 7/8" Bore)

Contact PCI for part numbers on units that include sprockets or V-Belt sheaves.

SINGLE - TYPE 'A' SPROCKET SIZES (using standard single strand roller chain)							
MODEL	SPROCKET NUMBER						
	25	35	40-41	50	60	80	100
MINIMUM # OF TEETH							
XM - 42	---	31	24	20	17	---	---
XM - 52	---	37	29	24	21	16	---

See Engineering Data (page 21) for Selection Guide, Installation Instructions, Dual Sprocket O.A.L. Dimension Chart and other application information.



"XB" Series - Clutch/Brake

Hub Start/Stop - End of Shaft Mount - Multiple Drive

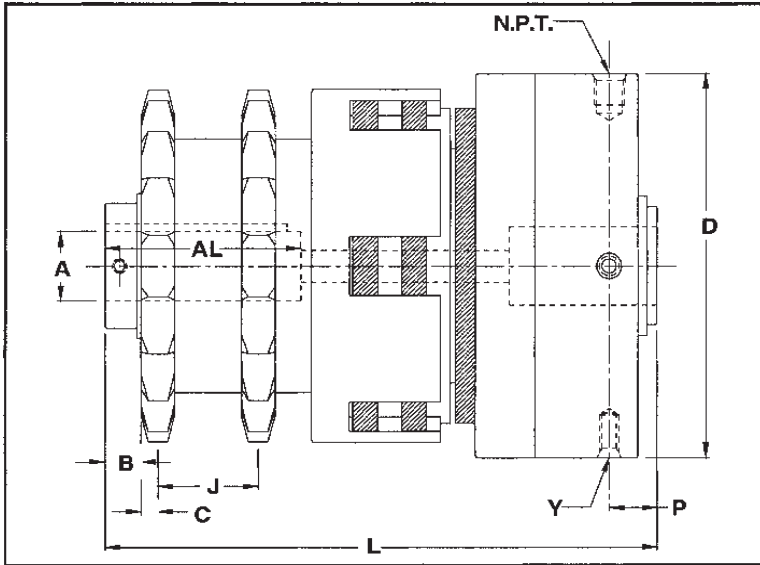

Supplied with sprockets or V-belt sheaves.

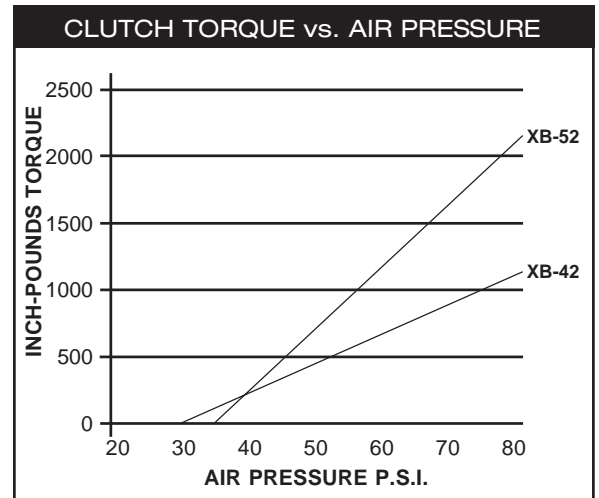

MODEL	A-BORE $\begin{smallmatrix} +.002 \\ -.000 \end{smallmatrix}$	AL	B	C	D	J	Y	N.P.T.	L	P
XB - 42	3/4 - 1	2.75	.44	*	4.88	*	1/4-20	1/8	*	.63
XB - 52	1 - 1 7/16	3.00	.50	*	5.88	*	5/16-18	1/8	*	.67

* Dimension varies depending on sprocket size - see chart below.

* VARIABLE DIMENSIONS								
DIMENSION	SPROCKET NUMBER							
	25	35	41	40	50	60	80	100
C	.04	.07	.10	.13	.16	.22	.27	.33
J	1.00	1.00	1.13	1.13	1.13	1.25	1.63	2.00
L	NOTE: Dimension varies depending on model and sprocket combination. (See pg. 21)							

SPRING SET BRAKE TORQUE	
MODEL	IN. - LBS.
XB - 42	150
XB - 52	375

HOW TO ORDER

Example: **XB - 42 - 14**

/ /

Model Bore Size in 1/16"
(14 = 14/16" or 7/8" Bore)

Contact PCI for part numbers on units that include sprockets or V-Belt sheaves.

SINGLE - TYPE 'A' SPROCKET SIZES (using standard single strand roller chain)							
MODEL	SPROCKET NUMBER						
	25	35	40-41	50	60	80	100
MINIMUM # OF TEETH							
XB - 42	---	31	24	20	17	---	---
XB - 52	---	37	29	24	21	16	---

See Engineering Data (page 21) for Selection Guide, Installation Instructions, Dual Sprocket O.A.L. Dimension Chart and other application information.



"XP" Series - Clutch/Brake

Drive Start/Stop - Thru Shaft Mount - Single Drive

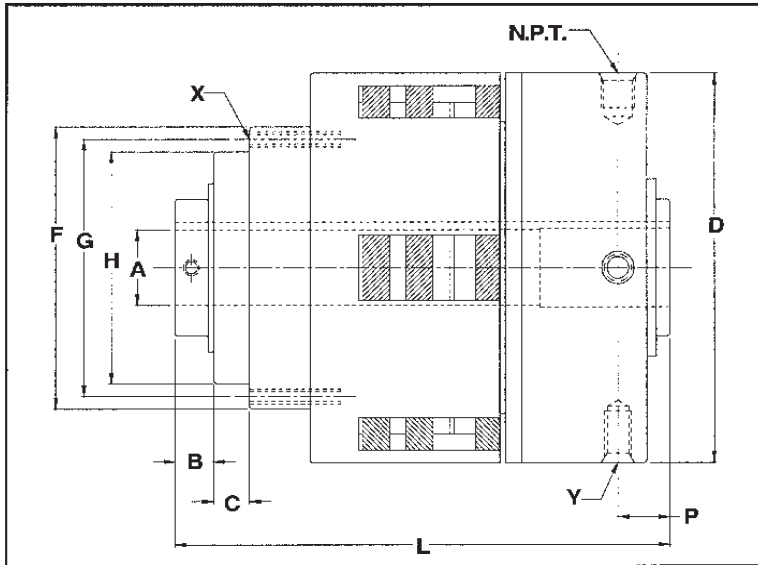

Available with a sprocket or V-belt sheave.

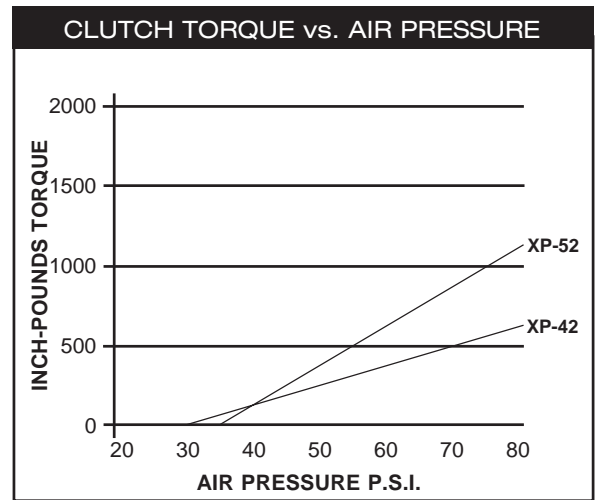

MODEL	A-BORE $\pm .002$ $-.000$	B	C	D	F	G	H $\pm .000$ $-.002$	X	Y	N.P.T.	L	P
XP - 42	3/4 - 1	.44	.34	4.48	3.23	2.95	2.677	[3] 8-32	1/4-20	1/8	5.85	.63
XP - 52	1 - 1 7/16	.50	.46	5.63	3.98	3.50	3.150	[3] 1/4-20	5/16-18	1/8	6.15	.71

SPRING SET BRAKE TORQUE	
MODEL	IN. - LBS.
XP - 42	95
XP - 52	240

HOW TO ORDER

Example: **XP - 42 - 14**

Model Bore Size in 1/16"
 (14 = 14/16" or 7/8" Bore)

Contact PCI for part numbers on units that include a sprocket or V-Belt sheave.

SINGLE - TYPE 'A' SPROCKET SIZES (using standard single strand roller chain)							
PILOT DIAMETER	SPROCKET NUMBER						
	25	35	40-41	50	60	80	100
H	MINIMUM # OF TEETH						
2.677	---	31	24	20	17	---	---
3.150	---	37	29	24	21	16	---

See Engineering Data (page 21) for Selection Guide, Installation Instructions and other application information.



“XQ” Series - Clutch/Brake

Drive Start/Stop - End of Shaft Mount - Single Drive

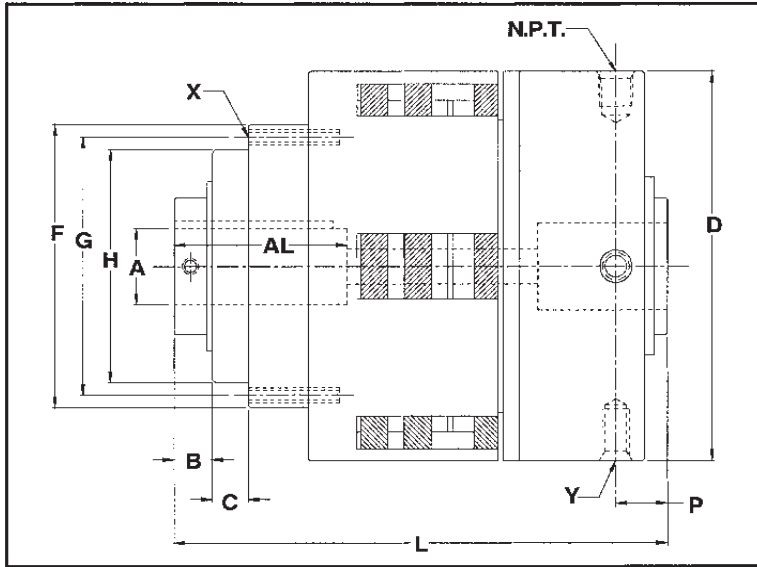

Available with a sprocket or V-belt sheave.

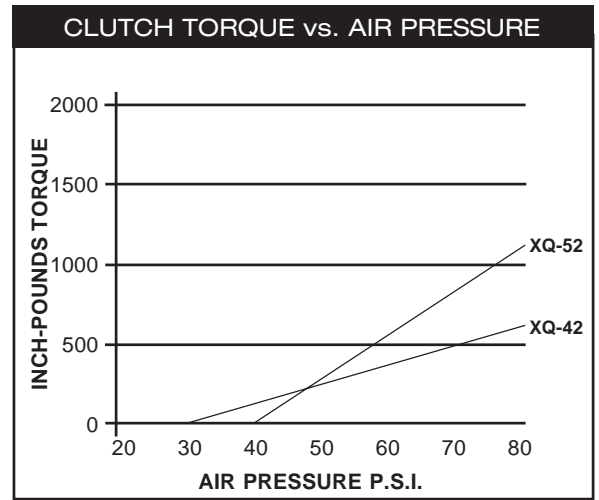

MODEL	A-BORE $\begin{smallmatrix} +.002 \\ -.000 \end{smallmatrix}$	AL	B	C	D	F	G	H $\begin{smallmatrix} +.000 \\ -.002 \end{smallmatrix}$	X	Y	L	P
XQ - 42	3/4 - 1	2.25	.44	.34	4.48	3.23	2.95	2.677	[3] 8-32	1/4-20	5.85	.63
XQ - 52	1 - 1 7/16	2.50	.50	.46	5.63	3.98	3.50	3.150	[3] 1/4-20	5/16-18	6.15	.71

SPRING SET BRAKE TORQUE	
MODEL	IN. - LBS.
XQ - 42	95
XQ - 52	240

HOW TO ORDER

Example: **XQ - 42 - 14**

Model
 Bore Size in 1/16"
 (14 = 14/16" or 7/8" Bore)

Contact PCI for part numbers on units that include a sprocket or V-Belt sheave.

SINGLE - TYPE 'A' SPROCKET SIZES (using standard single strand roller chain)							
PILOT DIAMETER	SPROCKET NUMBER						
	25	35	40-41	50	60	80	100
H	MINIMUM # OF TEETH						
2.677	---	31	24	20	17	---	---
3.150	---	37	29	24	21	16	---

See Engineering Data (page 21) for Selection Guide, Installation Instructions and other application information.



“XT” Series - Clutch/Brake

Drive Start/Stop - Thru Shaft Mount - Multiple Drive

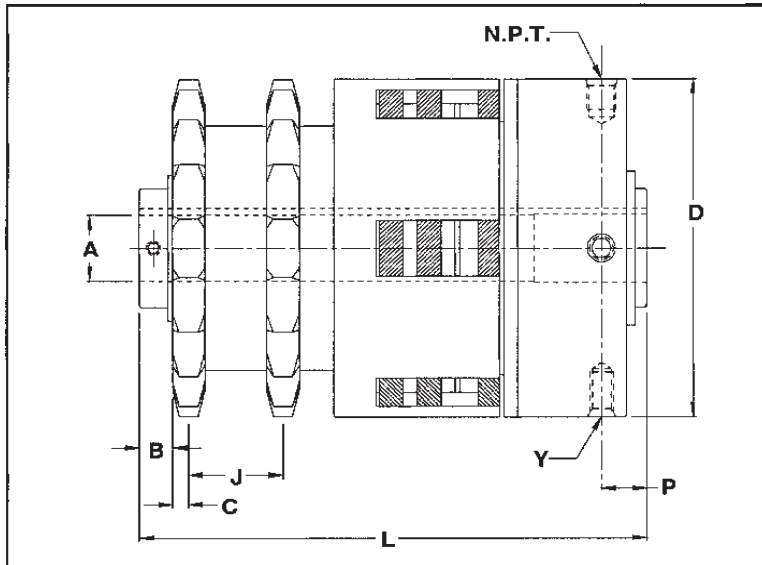

Supplied with sprockets or V-belt sheaves.

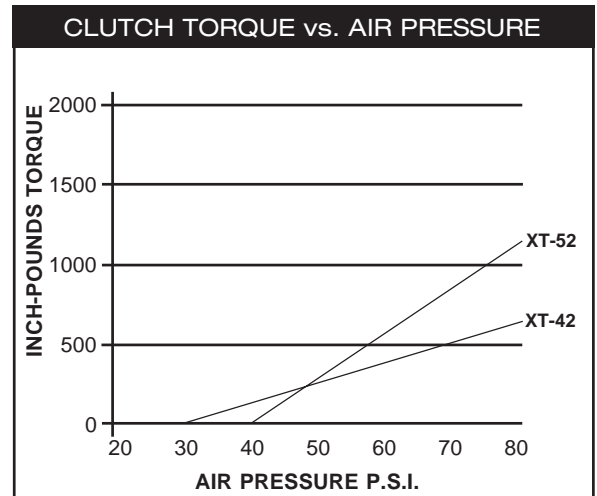

MODEL	A-BORE $\begin{smallmatrix} +.002 \\ -.000 \end{smallmatrix}$	B	C	D	J	Y	N.P.T.	L	P
XT - 42	3/4 - 1	.44	*	4.48	*	1/4-20	1/8	*	.63
XT - 52	1 - 1 7/16	.50	*	5.63	*	5/16-18	1/8	*	.71

* Dimension varies depending on sprocket size - see chart below.

* VARIABLE DIMENSIONS								
DIMENSION	SPROCKET NUMBER							
	25	35	41	40	50	60	80	100
C	.04	.07	.10	.13	.16	.22	.27	.33
J	1.00	1.00	1.13	1.13	1.13	1.25	1.63	2.00
L	NOTE: Dimension varies depending on model and sprocket combination. (See pg. 21)							

SPRING SET BRAKE TORQUE	
MODEL	IN. - LBS.
XT - 42	95
XT - 52	240

HOW TO ORDER

Example: **XT - 42 - 14**

/ /
 Model Bore Size in 1/16"
 (14 = 14/16" or 7/8" Bore)

Contact PCI for part numbers on units that include sprockets or V-Belt sheaves.

SINGLE - TYPE 'A' SPROCKET SIZES (using standard single strand roller chain)							
MODEL	SPROCKET NUMBER						
	25	35	40-41	50	60	80	100
MINIMUM # OF TEETH							
XT - 42	---	31	24	20	17	---	---
XT - 52	---	37	29	24	21	16	---

See Engineering Data (page 21) for Selection Guide, Installation Instructions, Dual Sprocket O.A.L. Dimension Chart and other application information.



“XJ” Series - Clutch/Brake

Drive Start/Stop - End of Shaft Mount - Multiple Drive

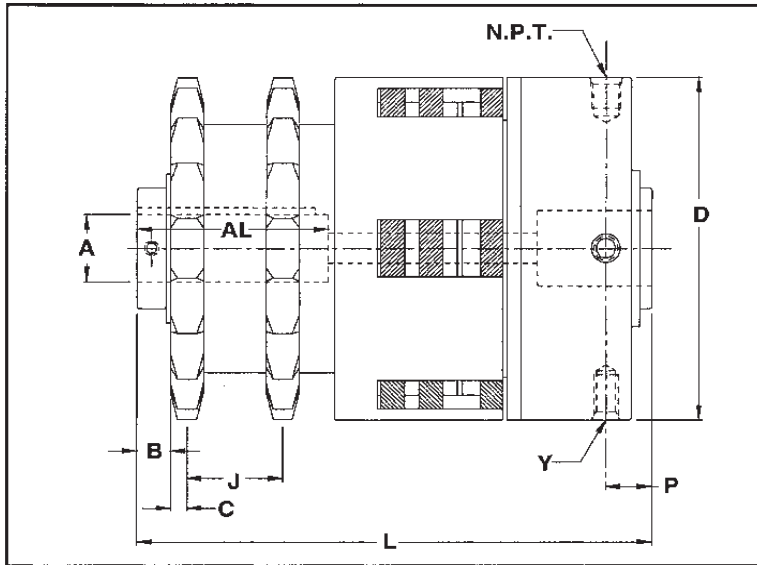

Supplied with sprockets or V-belt sheaves.

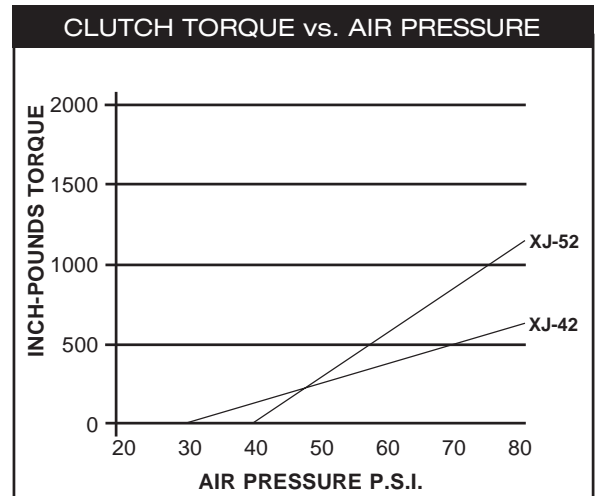

MODEL	A-BORE ^{+.002} / _{-.000}	AL	B	C	D	J	Y	N.P.T.	L	P
XJ - 42	3/4 - 1	2.75	.44	*	4.48	*	1/4-20	1/8	*	.63
XJ - 52	1 - 1 7/16	3.00	.50	*	5.63	*	5/16-18	1/8	*	.71

* Dimension varies depending on sprocket size - see chart below.

* VARIABLE DIMENSIONS								
DIMENSION	SPROCKET NUMBER							
	25	35	41	40	50	60	80	100
C	.04	.07	.10	.13	.16	.22	.27	.33
J	1.00	1.00	1.13	1.13	1.13	1.25	1.63	2.00
L	NOTE: Dimension varies depending on model and sprocket combination. (See pg. 21)							

SPRING SET BRAKE TORQUE	
MODEL	IN. - LBS.
XJ - 42	95
XJ - 52	240

HOW TO ORDER

Example: **XJ - 42 - 14**

/ /

Model Bore Size in 1/16"
(14 = 14/16" or 7/8" Bore)

Contact PCI for part numbers on units that include sprockets or V-Belt sheaves.

SINGLE - TYPE 'A' SPROCKET SIZES (using standard single strand roller chain)							
MODEL	SPROCKET NUMBER						
	25	35	40-41	50	60	80	100
MINIMUM # OF TEETH							
XJ - 42	---	31	24	20	17	---	---
XJ - 52	---	37	29	24	21	16	---

See Engineering Data (page 21) for Selection Guide, Installation Instructions, Dual Sprocket O.A.L. Dimension Chart and other application information.



“BK” Series - Brake Air Set - Thru Shaft Mount - Back Mounted

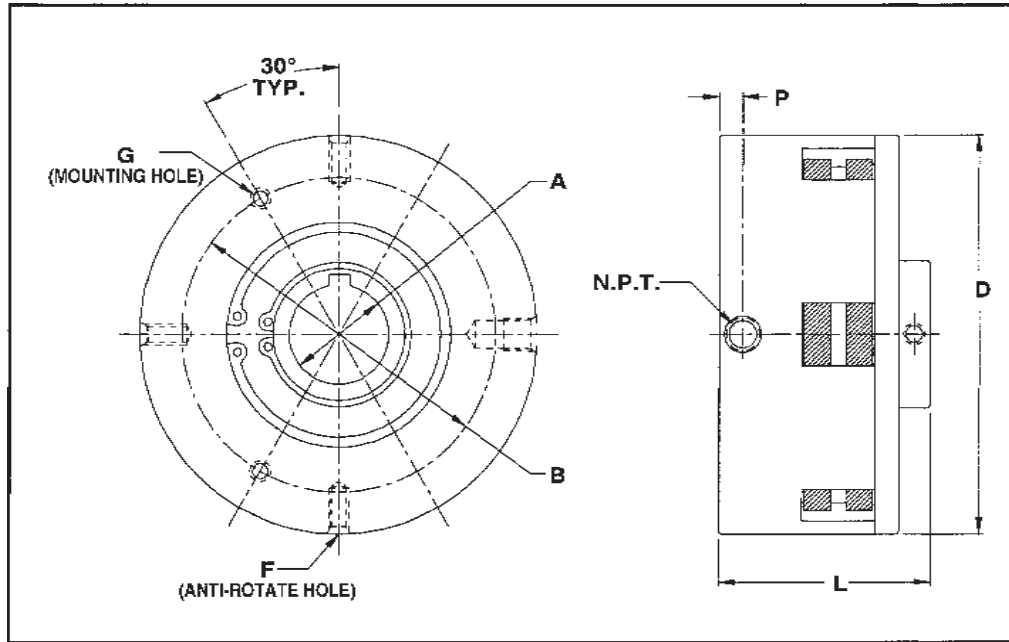

MODEL	A-BORE $\begin{smallmatrix} +.002 \\ -.000 \end{smallmatrix}$	B	D	F	G	L	N.P.T.	P
BK - 32	1/2 - 7/8	3.00	3.88	[3] 1/4-20	[2] 1/4-20	2.24	1/8	.34
BK - 42	3/4 - 1 3/16	3.75	4.75	[3] 1/4-20	[2] 1/4-20	2.50	1/8	.31
BK - 52	1 - 1 7/16	4.50	6.00	[3] 1/4-20	[2] 1/4-20	2.54	1/8	.37

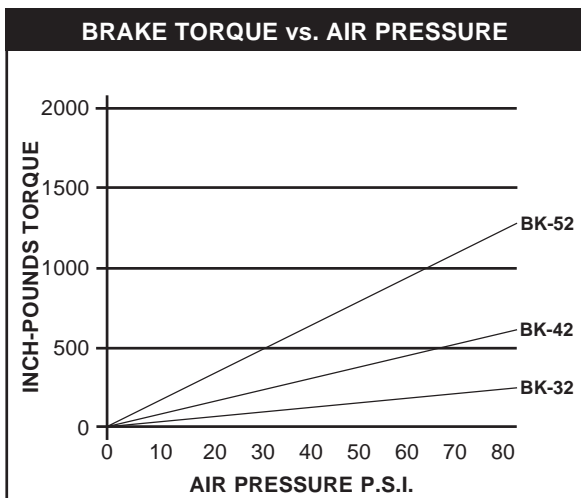

HOW TO ORDER

Example: **BK - 42 - 14**

Model Bore Size in 1/16"
(14 = 14/16" or 7/8" Bore)

See Engineering Data (page 21) for Selection Guide, Installation Instructions and other application information.



“BF” Series - Brake Air Set - Thru Shaft Mount - Flange Mounted

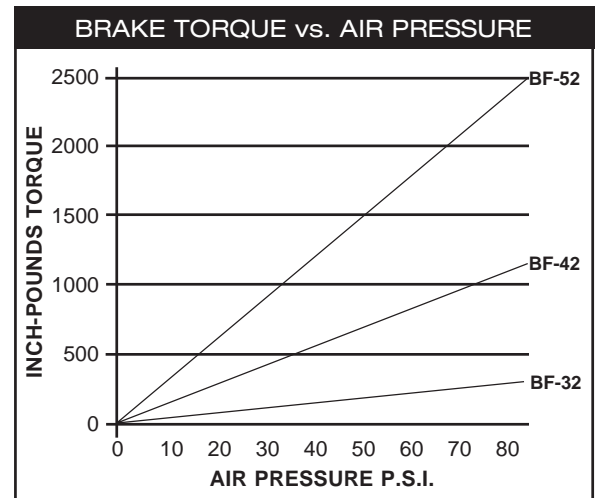
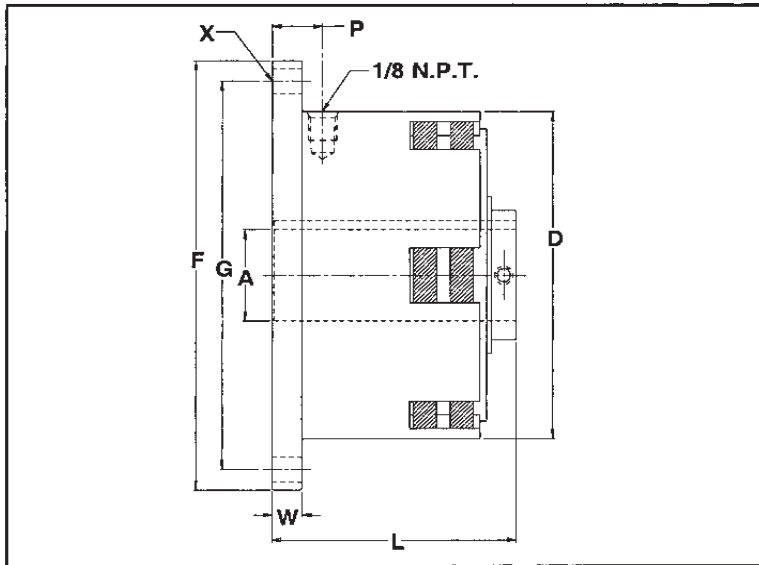

MODEL	A-BORE $\begin{smallmatrix} +.002 \\ -.000 \end{smallmatrix}$	D	F	G	L	W	X	P
BF - 32	5/8 - 1	3.48	4.75	4.00	2.82	.30	[4] .27	.67
BF - 42	3/4 - 1 1/4	4.48	5.88	5.31	3.35	.41	[6] .34	.78
BF - 52	1 - 1 7/16	5.63	7.20	6.50	3.40	.75	[8] .34	1.09

HOW TO ORDER

Example: **BF - 42 - 14**

Model

Bore Size in 1/16"

(14 = 14/16" or 7/8" Bore)

See Engineering Data (page 21) for Selection Guide, Installation Instructions and other application information.



"TL" Series - Torque Limiter

Bronze Bushing Pilot - Thru Shaft Mount - Single Drive

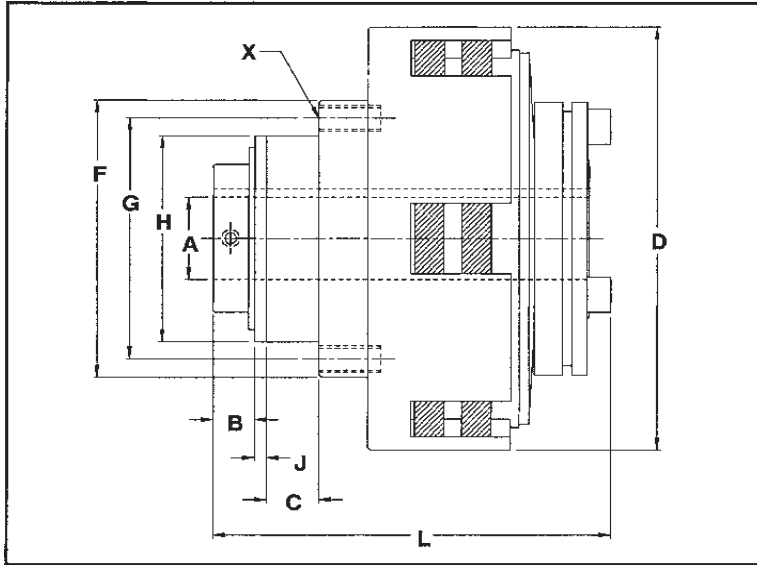

Available with a sprocket.

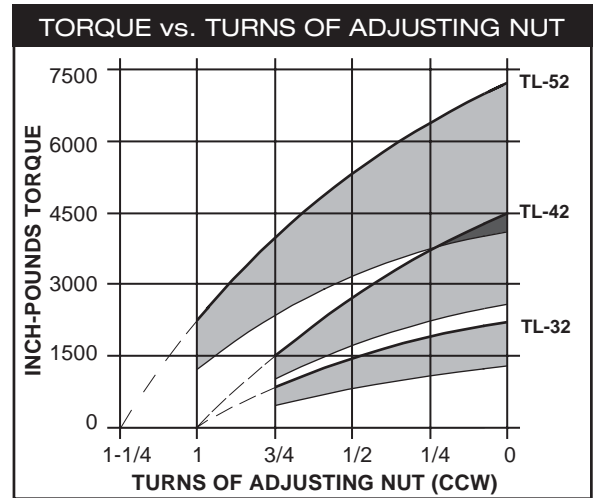

— Upper Limit - - - - - Non-Usable Range
 — Lower Limit ▨ 40% Operating Range

MODEL	A-BORE $^{+.002}_{-.000}$	B	C	D	F	G	H $^{+.000}_{-.002}$	J	X	L*
TL - 32	5/8 - 1	.44	.43	3.48	2.63	2.31	2.00	.13	[3] 10-32	3.29
TL - 42	3/4 - 1 1/4	.44	.56	4.56	2.94	2.56	2.19	.13	[6] 10-32	4.26
TL - 52	1 - 1 7/16	.49	.63	5.73	3.75	3.12	2.75	.13	[6] 1/4-20	4.89

* Maximum length at full usable adjustment

HOW TO ORDER

Example: **TL - 42 - 14**

/ /

Model Bore Size in 1/16"
(14 = 14/16" or 7/8" Bore)

Contact PCI for part numbers on units that include a sprocket.

SINGLE - TYPE 'A' SPROCKET SIZES (using standard single strand roller chain)							
PILOT DIAMETER	SPROCKET NUMBER						
	25	35	40-41	50	60	80	100
H	MINIMUM # OF TEETH						
2.00	38	26	20	17	---	---	---
2.19	41	29	22	19	16	---	---
2.75	52	36	27	23	20	16	---

See Engineering Data (page 21) for Selection Guide, Installation Instructions, Dual Sprocket O.A.L. Dimension Chart and other application information.



“MC” Series - Modular Coupler

“MH” Series - Modular Clutch Housing

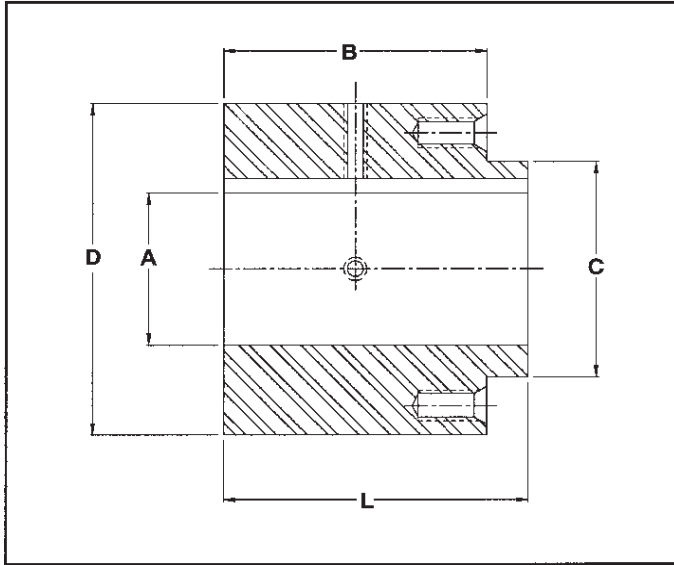

Set screws included.

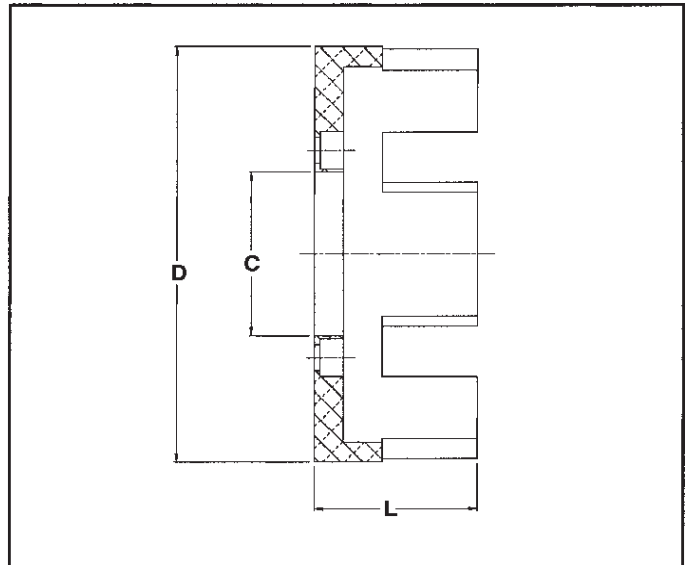

Mounting screws included.

MODEL	A-BORE $^{+.002}$ $_{-.000}$	B	C	D	L
MC - 30	5/8 - 1	1.75	1.38	1.97	2.03
MC - 40	3/4 - 1 1/4	2.00	1.75	2.72	2.34
MC - 50	1 - 1 7/16	2.50	1.97	2.97	2.91

MODEL	C	D	L
MH - 32	1.38	3.48	1.27
MH - 42	1.75	4.48	1.76
MH - 52	1.97	5.63	1.87

HOW TO ORDER

Example: **MC - 30 - 14**

Model Bore Size in 1/16"
 (14 = 14/16" or 7/8" Bore)

HOW TO ORDER

Example: **MH - 32 - 00**

Model N/A
 (No Bore Size)

Modular (in-line) assemblies are used for coupling together two independent in-line shafts of the same or differing sizes.

Constructing a complete and fully operational modular (in-line) assembly requires three individual items:

- (1) Modular “MP” clutch mechanism or (1) modular “MF” torque limiter mechanism
- (1) Modular “MC” coupler
- (1) Modular “MH” clutch housing

Example: Clutch mechanism MP-42 requires coupler MC-40 and clutch housing MH-42.

See Engineering Data (page 23) for Selection Guide, Installation Instructions and other application information.

Overall length of complete modular assembly = (mechanism dim. “L” + set pt. “C” + coupler dim. “L”)



“MP” Series - Modular Clutch Mechanism

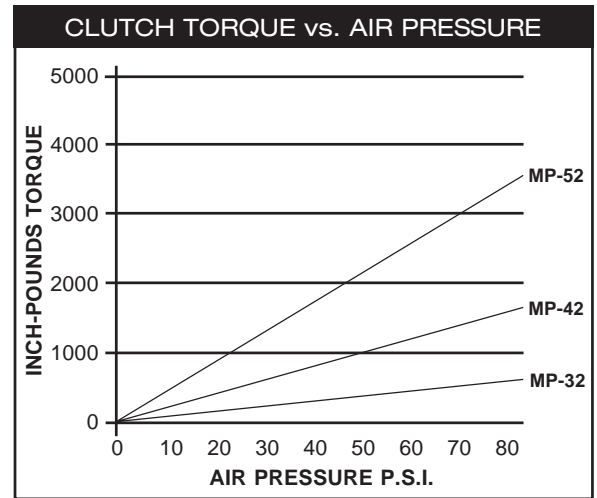
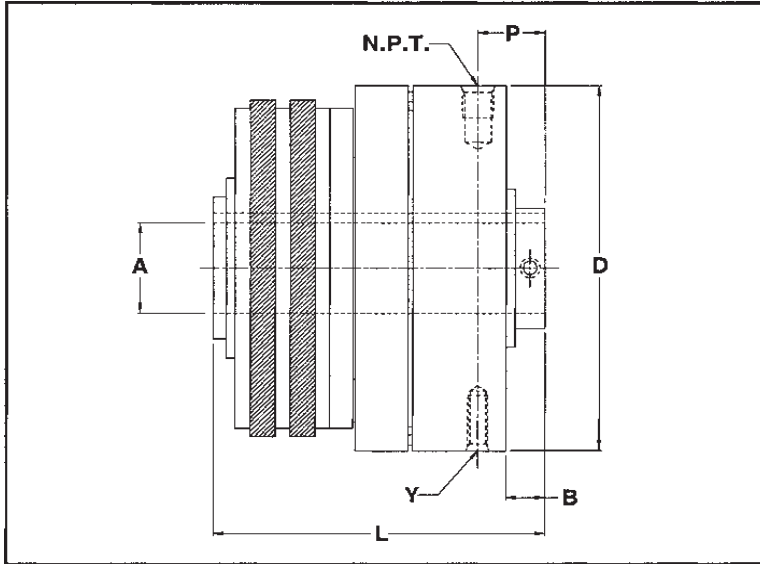

MODEL	A-BORE $\begin{smallmatrix} +.002 \\ -.000 \end{smallmatrix}$	B	D	Y	N.P.T.	L	P
MP - 32	5/8 - 1	.44	3.48	1/4-20	1/8	3.42	.77
MP - 42	3/4 - 1 1/4	.49	4.56	1/4-20	1/8	4.20	.87
MP - 52	1 - 1 7/16	.55	5.73	1/4-20	1/8	4.39	.94

HOW TO ORDER

Example: MP - 42 - 14

Model Bore Size in 1/16"
(14 = 14/16" or 7/8" Bore)

Modular (in-line) assemblies are used for coupling together two independent in-line shafts of the same or differing sizes.

Constructing a complete and fully operational modular (in-line) assembly requires three individual items:

- (1) Modular “MP” clutch mechanism or (1) modular “MF” torque limiter mechanism
- (1) Modular “MC” coupler
- (1) Modular “MH” clutch housing

Example: Clutch mechanism MP-42 requires coupler MC-40 and clutch housing MH-42.

See Engineering Data (page 23) for Selection Guide, Installation Instructions and other application information.

Overall length of complete modular assembly = (mechanism dim. “L” + set pt. “C” + coupler dim. “L”)



“MF” Series - Modular Torque Limiter Mechanism

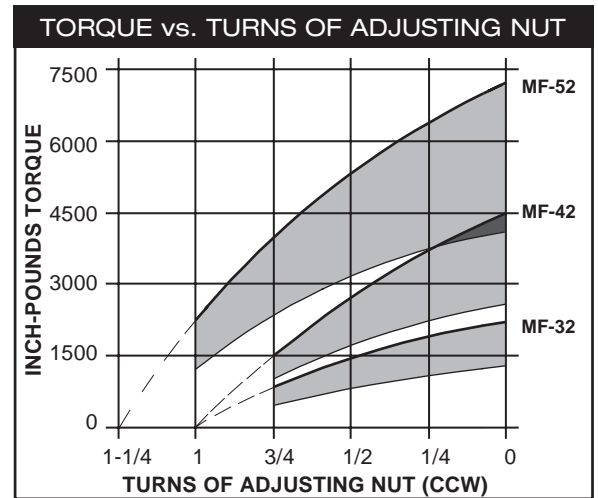
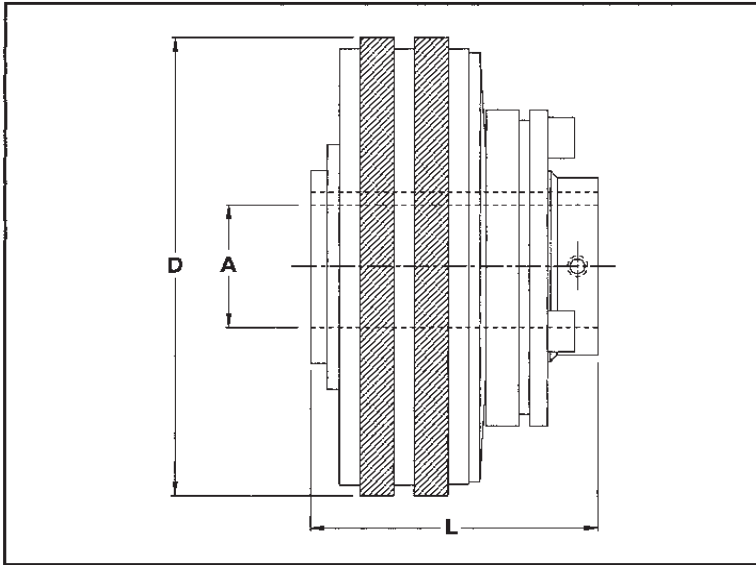

Upper Limit
 Lower Limit
 Non-Usable Range
 40% Operating Range

MODEL	A-BORE $\begin{matrix} +.002 \\ -.000 \end{matrix}$	D	L
MF - 32	5/8 - 1	3.47	2.05
MF - 42	3/4 - 1 1/4	4.47	2.58
MF - 52	1 - 1 7/16	5.62	2.84

HOW TO ORDER

Example: MF - 42 - 14
 /
Model **Bore Size in 1/16"**
 (14 = 14/16" or 7/8" Bore)

Modular (in-line) assemblies are used for coupling together two independent in-line shafts of the same or differing sizes.

Constructing a complete and fully operational modular (in-line) assembly requires three individual items:

- (1) Modular “MP” clutch mechanism or (1) modular “MF” torque limiter mechanism
- (1) Modular “MC” coupler
- (1) Modular “MH” clutch housing

Example: Clutch mechanism MP-42 requires coupler MC-40 and clutch housing MH-42.

See Engineering Data (page 23) for Selection Guide, Installation Instructions and other application information.

Overall length of complete modular assembly = (mechanism dim. “L” + set pt. “C” + coupler dim. “L”)



Engineering Data

Torque Ratings/Wear-In

Torque ratings shown in this catalog are calculated theoretical values. New unit torques are generally about 40% less than these values. Torque limiter charts show this 40% operating range while clutch, clutch/brake and brake charts do not. After an initial period of cycling, burnishing/wear-in will occur between the friction disks and the coupling plates, thereby increasing the torque values toward the theoretical ratings. Excessive wear-in may decrease torque values of torque limiters, thereby requiring readjustment. The length of time or number of cycles for wear-in to occur will vary depending on each unique application.

Clutches, Clutch/Brakes and Brakes

Selection Guide:

- 1.) Determine system maximum operating torque delivered to clutch, clutch/brake or brake location. (Spike and start-up conditions should be considered.)
- 2.) Increase value from Step-1 (multiply) by safety factor (1.2 - 2.0). (See Page 24)
- 3.) Select style (series) of clutch, clutch/brake or brake required.
- 4.) Compare value from Step-2 with rated capacity values from applicable torque charts.
- 5.) Select appropriate size (model) clutch, clutch/brake or brake required.

**All clutches, clutch/brakes and brakes in this catalog are designed for occasional start/stops of no more than (5) cycles per minute. They are not intended for high cycle, high inertia or tension control applications. A clutch, clutch/brake or brake should never be used at the maximum rated torque value.*

Clutch and Clutch/Brake Installation:

- 1.) Apply light coating of anti-seize lube to mounting shaft.
- 2.) Place keystick into mounting shaft keyway.
- 3.) Align clutch or clutch/brake keyway with that of mounting shaft keyway and gently slide unit on.
- 4.) Ensure clutch or clutch/brake drive is in-line with associated drive to avoid axial chain pull.
- 5.) Tighten set screws of clutch or clutch/brake shaft after unit is in correct position.
- 6.) Attach torque arm to stationary piston housing of clutch/brake or of applicable clutch. Torque arm may be in the form of a bracket, stopping peg or a strap mounted between piston housing anti-rotate holes and a fixed member. Always use a non-rigid restraint.
- 7.) Attach air line fitting to air port hole of piston housing or rotary union taking care not to cross-thread. Use a small amount of joint compound to help prevent possible leaks.

Brake Installation:

- 1.) Apply light coating of anti-seize lube to mounting shaft.
- 2.) Place keystick into mounting shaft keyway.
- 3.) Align brake keyway with that of mounting shaft keyway and gently slide unit on.
- 4.) Attach torque arm or mount brake unit to a fixed member using anti-rotate holes or mounting holes. Torque arm may be in the form of a bracket, stopping peg or a strap.
- 5.) Tighten set screws of brake shaft after unit is in correct position.
- 6.) Attach air line fitting to air port hole of brake housing taking care not to cross-thread. Use a small amount of joint compound to help prevent possible leaks.

DUAL SPROCKET OVERALL LENGTH VARIABLE DIMENSION "L" OR "L1" (EXCLUDING ROTARY UNION)								
MODEL	SPROCKET NUMBER							
	25	35	41	40	50	60	80	100
CM-31	4.678	4.733	4.918	4.973	5.033	5.273	----	----
CM-32	5.021	5.076	5.261	5.316	5.376	5.616	----	----
CM-41	5.527	5.582	5.767	5.822	5.882	6.122	----	----
CM-42	6.027	6.082	6.267	6.322	6.382	6.622	----	----
CM-51	5.960	6.015	6.200	6.255	6.315	6.555	7.030	7.535
CM-52	6.460	6.515	6.700	6.755	6.815	7.055	7.530	8.035
CE-32	4.338	4.393	4.578	4.633	4.693	4.933	----	----
CE-33	4.681	4.736	4.921	4.976	5.036	5.276	----	----
CE-42	4.970	5.025	5.210	5.265	5.325	5.565	----	----
CE-52	5.305	5.360	5.545	5.600	5.660	5.900	6.375	6.880
CE-53	5.804	5.859	6.044	6.099	6.159	6.399	5.874	7.379
XM-42	----	6.571	6.756	6.811	6.871	7.111	----	----
XM-52	----	6.885	7.070	7.125	7.185	7.425	7.900	----
XB-42	----	6.571	6.756	6.811	6.871	7.111	----	----
XB-52	----	6.885	7.070	7.125	7.185	7.425	7.900	----
XT-42	----	6.326	6.511	6.566	6.626	6.866	----	----
XT-52	----	6.758	6.943	6.998	7.058	7.298	7.773	----
XJ-42	----	6.326	6.511	6.566	6.626	6.866	----	----
XJ-52	----	6.758	6.943	6.998	7.058	7.298	7.773	----



Torque Limiters

Selection Guide: (Refer to Torque Range Diagram below)

- 1.) Determine torque protection range where torque limiter is required to work within.
 - A.) Determine system maximum operating torque delivered to torque limiter location. (Spike and start-up conditions should be considered.)
 - B.) Increase value from Step-1A (multiply) by a safety factor (1.2 - 2.0). (See Page 24)
This is lower limit of torque protection range.
 - C.) Determine system failure torque where damage will occur.
 - D.) Decrease value from Step-1C (divide) by safety factor (1.2 - 2.0). (See Page 24)
This is upper limit of torque protection range.
- 2.) Compare torque protection range from Step-1 with torque limiter 40% operating ranges (from torque limiter torque chart - Page 17) at various adjusting nut settings. The entire 40% operating range of the torque limiter must lie within the torque protection range without overlapping limit values.
- 3.) Select appropriate size (model) torque limiter capable of operating within torque protection range.

**Torque limiters are not designed to function as clutches, must not be the primary source used to engage and disengage drive systems and should never be used to protect personnel. Torque limiters are well suited for low speed mechanical drives where slippage is infrequent and of short duration.*

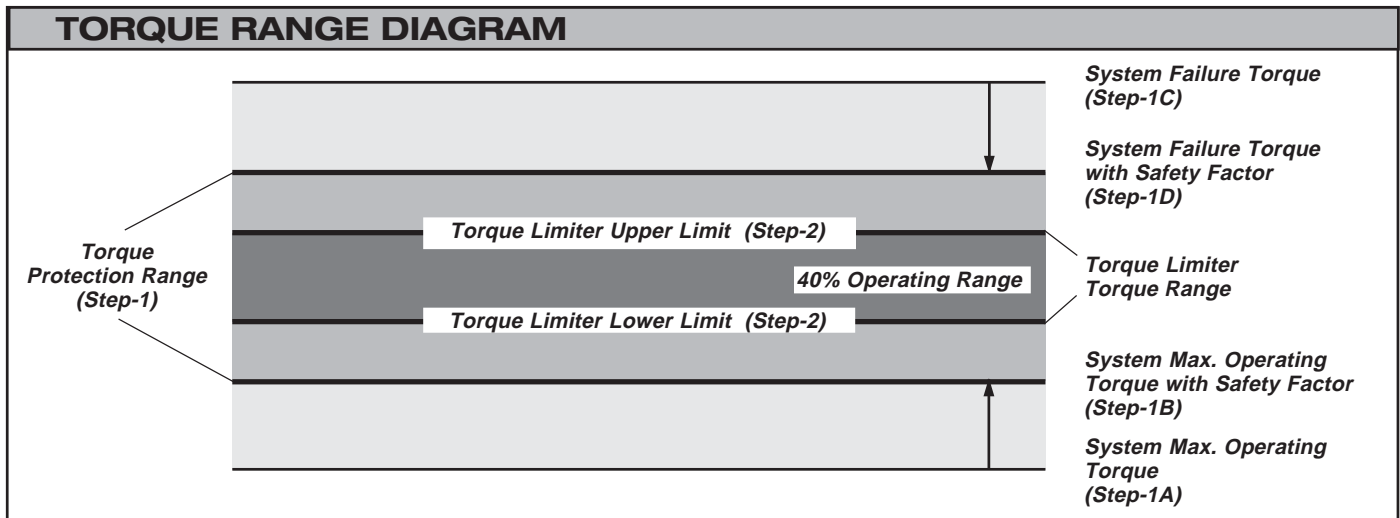

Torque Limiter Installation:

- 1.) Apply light coating of anti-seize lube to mounting shaft.
- 2.) Place keystone into mounting shaft keyway.
- 3.) Align torque limiter keyway with that of mounting shaft keyway and gently slide unit on.
- 4.) Ensure torque limiter drive is in-line with associated drive to avoid axial chain pull.
- 5.) Tighten set screws of torque limiter shaft after unit is in correct position.

Torque Limiter Adjustment Instructions:

- 1.) To increase torque setting:
 - A.) Loosen (3) socket head cap screws until adjusting nut and disk spring are loose (about 1/4").
 - B.) Hand-tighten adjusting nut until slightly snug.
 - C.) Retighten (3) socket head cap screws until heads bottom-out flush. This will provide the maximum torque. (Units are shipped at maximum torque setting).
- 2.) To reduce torque setting:
 - A.) Loosen (3) socket head cap screws until adjusting nut and disk spring are loose (about 1/4").
 - B.) Loosen adjusting nut as required (see torque limiter torque chart).
 - C.) Retighten (3) socket head cap screws until heads bottom-out flush.



Modular (In-Line) Units

Modular Clutch Selection Guide:

- 1.) Determine system maximum operating torque delivered to modular clutch location. (Spike and start-up conditions should be considered.)
- 2.) Increase value from Step-1 (multiply) by safety factor (1.2 - 2.0). (See Page 24)
- 3.) Compare value from Step-2 with rated capacity values from modular clutch mechanism torque chart. (See Page 19)
- 4.) Select appropriate size (model) modular clutch mechanism required.
- 5.) Select corresponding (model) modular coupler and modular clutch housing (See Page 18) to match size of modular clutch mechanism selected in Step-4. It is acceptable for mechanism and coupler shafts to have different bore sizes.
**All modular (in-line) clutches in this catalog are designed for occasional start/stops of no more than (5) cycles per minute. They are not intended for high cycle, high inertia or tension control applications. A modular clutch should never be used at the maximum rated torque value.*

Modular Torque Limiter Selection Guide: (Refer to Torque Range Diagram - Page 22)

- 1.) Determine torque protection range where modular torque limiter is required to work within.
 - A.) Determine system maximum operating torque delivered to modular torque limiter location. (Spike and start-up conditions should be considered.)
 - B.) Increase value from Step-1A (multiply) by a safety factor (1.2 - 2.0). (See Page 24)
This is lower limit of torque protection range.
 - C.) Determine system failure torque where damage will occur.
 - D.) Decrease value from Step-1C (divide) by safety factor (1.2 - 2.0). (See Page 24)
This is upper limit of torque protection range.
- 2.) Compare torque protection range (Step-1) with modular torque limiter mechanism 40% operating ranges (from modular torque limiter mechanism torque chart - Page 20) at various adjusting nut settings. The entire 40% operating range of the modular torque limiter mechanism must lie within the torque protection range without overlapping limit values.
- 3.) Select appropriate size (model) modular torque limiter mechanism capable of operating within torque protection range.
- 4.) Select corresponding (model) modular coupler and modular clutch housing (Page 18) to match size of modular torque limiter mechanism selected in Step-3. It is acceptable for mechanism and coupler shafts to have different bore sizes.
**Modular (in-line) torque limiters are not designed to function as clutches, must not be the primary source used to engage and disengage drive systems and should never be used to protect personnel. Modular torque limiters are well suited for low speed mechanical drives where slippage is infrequent and of short duration.*

Modular Clutch/Modular Torque Limiter Installation: (Refer to Modular Installation Chart and Drawing - Page 24)

- 1.) Verify driving and driven shaft parallelism misalignment is within charted tolerance. Measure parallelism across overall length of MC coupler and MP or MF mechanism shafts.
- 2.) Apply light coating of anti-seize lube to driven and driving shafts.
- 3.) Place keystone into driven and driving shaft keyways.
- 4.) Align MP/MF mechanism keyway with that of driving shaft (friction disks facing driven shaft side) and gently slide unit on.
- 5.) Assemble MC coupler shaft and MH clutch housing using mounting screws provided with housing. Align holes, insert screws and tighten securely.
- 6.) Align MC/MH assembly keyway with that of driven shaft (MH housing facing driving shaft side) and gently slide unit on.
- 7.) Slide MP or MF mechanism and MC/MH assembly together while aligning friction disk tabs with MH housing slots until MC coupler and MP or MF mechanism shafts come in contact with each other.
- 8.) Measure dimension at location "A" for reference. Separate halves until "A"-dimension is increased by set point value "C" shown in chart. Set point value is initial spacing between MC coupler and MP or MF mechanism shafts. Driving and driven shafts should be 1-1/2" min. inside MC coupler and MP or MF mechanism shafts. Tighten all set screws securely.
- 9.) Verify assembly angular misalignment is within charted tolerance. Angular tolerance is the difference between dimensions "A" and "B" which are measured at 180° apart.
- 10.) Attach torque arm to stationary piston housing of modular clutch mechanism. Torque arm may be in the form of a bracket, stopping peg or a strap mounted between piston housing anti-rotate holes and a fixed member. Always use a non-rigid restraint. *Not applicable to modular torque limiter.
- 11.) Attach air line fitting to air port hole of piston housing, taking care not to cross-thread. Use a small amount of joint compound to help prevent possible leaks. *Not applicable to modular torque limiter.

Modular Torque Limiter Adjustment Instructions:

- See Torque Limiter Adjustment Instructions - Page 22.



MODULAR CLUTCH/MODULAR TORQUE LIMITER INSTALLATION SPECIFICATIONS

(MC/MH/MP) OR (MC/MH/MF) MODULAR ASSEMBLY SIZE	MAXIMUM DRIVING/DRIVEN SHAFT PARALLELISM MISALIGNMENT (in.)	MAXIMUM ASSEMBLY ANGULAR MISALIGNMENT ("B" - "A") (in.)	(MC/MP) OR (MC/MF) SHAFT SET POINT "C" (in.)	MAXIMUM DRIVING/DRIVEN SHAFT AXIAL FLOAT (in.)
3 in.	0.015	0.045	0.030	+/- .030 FROM SET POINT
4 in.	0.015	0.060	0.045	+/- .045 FROM SET POINT
5 in.	0.015	0.075	0.090	+/- .045 FROM SET POINT

* Tabulated values are based on individual misalignment capabilities and may not be combined.

MODULAR CLUTCH/MODULAR TORQUE LIMITER INSTALLATION DRAWING

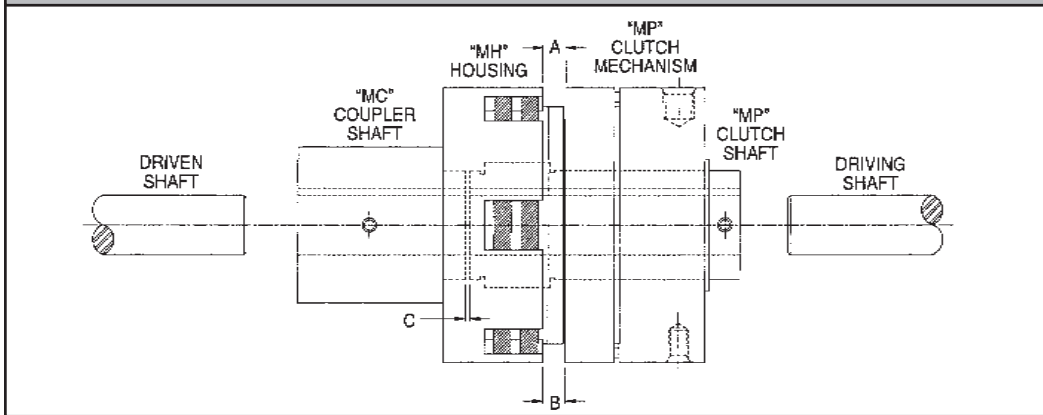

Safety Factors

Always increase (multiply) by a safety factor of 1.2 to 2.0 when calculating system maximum torque.

Example: System Maximum Torque x Safety Factor = Appropriate Torque Rating
 1000 in.-lbs. x (1.2 to 2.0) = (1200 to 2000) in.-lbs.

Always decrease (divide) by a safety factor of 1.2 to 2.0 when calculating system failure torque.

Example: System Failure Torque / Safety Factor = Appropriate Torque Rating
 8000 in.-lbs. / (1.2 to 2.0) = (6666 to 4000) in.-lbs.

General Notes

- All keyways are standard size.
- Always use flexible connection between airline and air fitting.
- Never rigidly mount stationary-style piston housings.
- Recommended mounting shaft size = nominal shaft size with (+.000 / -.001) tolerance.
- Always use filtered, lubricated and regulated air with pneumatic units.
- Never use units in conditions outside of intended operating specifications.
- All multiple drive units are supplied with sprockets or V-Belt sheaves.
- Hardened tooth sprockets available at additional cost.
- Internal rotary union style is supplied, unless otherwise noted.

Rotary Union Options

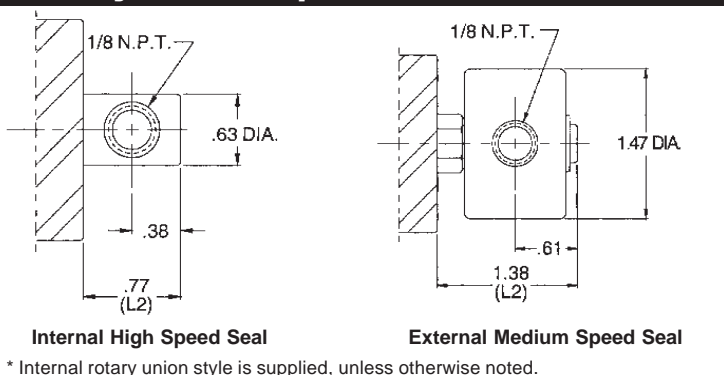

* Internal rotary union style is supplied, unless otherwise noted.

Rebuild Kits

Rebuild kits are available from stock for all standard products. Typical kits include friction disks, springs and o-rings. Proper disassembly and reassembly of units is highly sensitive and should only be done by qualified personnel. It is recommended that units are returned to PCI for rebuilding so warranty is not voided. Please contact PCI's customer service department if assistance is required.

Specials

For applications requiring a clutch, clutch/brake, brake or torque limiter not listed in this catalog, please contact PCI's customer service department.

PRODUCTS MANUFACTURED BY PCI

PCI Track Rollers:

- Machine ground with ball bearings or tapered roller bearings to accommodate thrust loads
- Stud and Yoke Styles
Available in:
 - Regreaseable
 - Nylon
 - NEW!** Stainless steel
 - High temperature
 - Custom designs



PCI Cam Followers:

- Manufactured with needle bearings for radial load applications
- 2" through 10" diameter in both Stud and Yoke styles in stock

PCI Pneumatic Clutches:

- Clutches, brakes, clutch/brakes, torque limiters
- Torque capacities from 0-6300 in.-lbs
- Bolt-on drives, sprockets, v-belt sheaves and gears
- Virtually maintenance-free
- Custom styles and sizes per specification

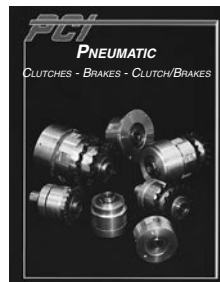

PCI Traction Wheel Hub Assemblies:

- In stock and available for quick shipment
- Interchangeable with other manufacturers' hubs



PCI Standard Duty Pulleys & Machined Pulleys:

- 2" to 12" diameter
- Various hub styles
- V-groove styles
- Trapezoidal crown for maximum concentricity and reduced belt wear
- Available with lagging



PCI Stainless Steel Pulleys:

- Sanitary/Food Grade
- Corrosive/Washdown
- Available with lagging



PCI Heavy Duty Pulleys:

- 14" diameters and larger
- 72" overall face length
- Various hub styles
- Flat face or crowned for maximum concentricity and reduced belt wear
- Available with lagging
- Mine duty and spiral styles available

PCI Wing Pulleys:

- Self-cleaning
- 6" diameters and larger
- Mine duty and spiral styles available

PCI Take-Up Frames:

- Available in Wide Slot and Narrow Slot styles
- Capable of mounting inside, outside or as part of the conveyor frame

PCI Take-Up Frame Covers:



- Keep debris away from your bearings and adjusting screw
- Cover rotating shafting and other moving parts as a safety feature
- One style fits on existing PCI and Dodge frames
- One style fits over existing Take-up Frames

**Available Through a
Distributor in Your Area!**