

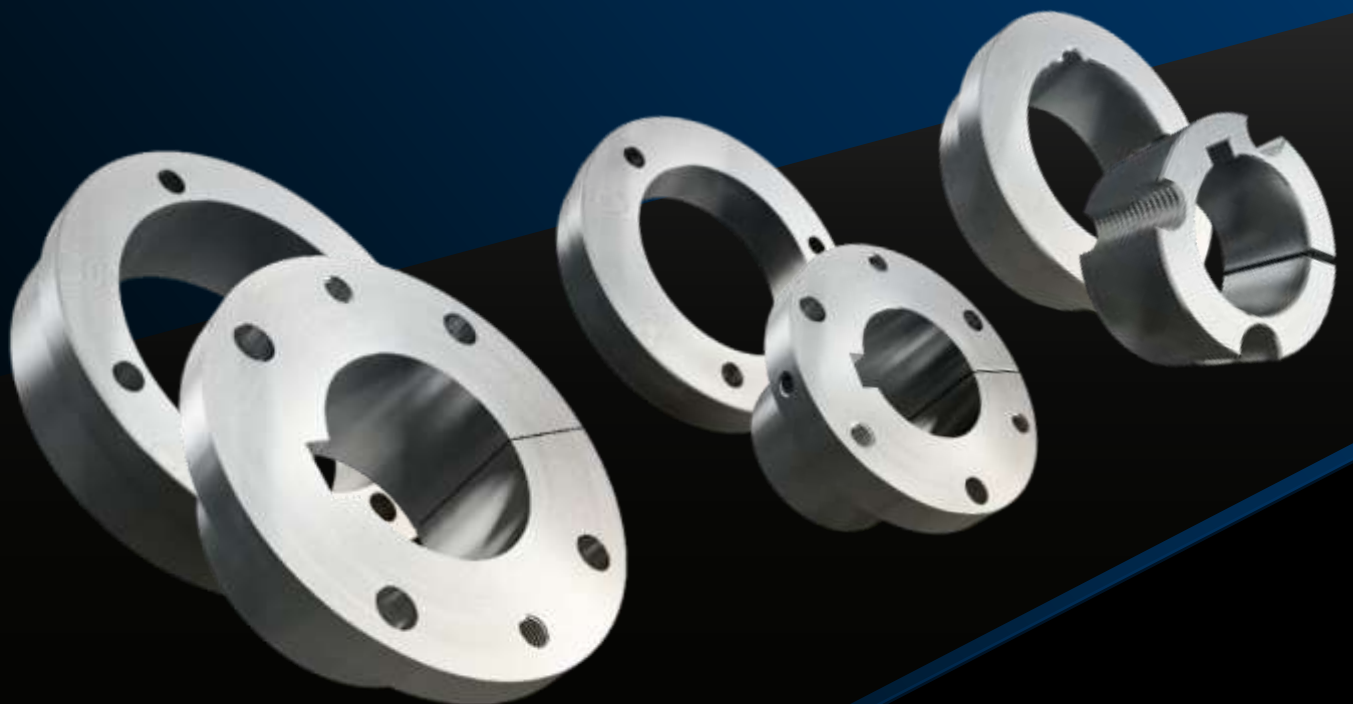

STAINLESS STEEL HUBS & BUSHINGS



ACCESSORIES

Stainless Steel Compression Hubs & Bushings XT® Style

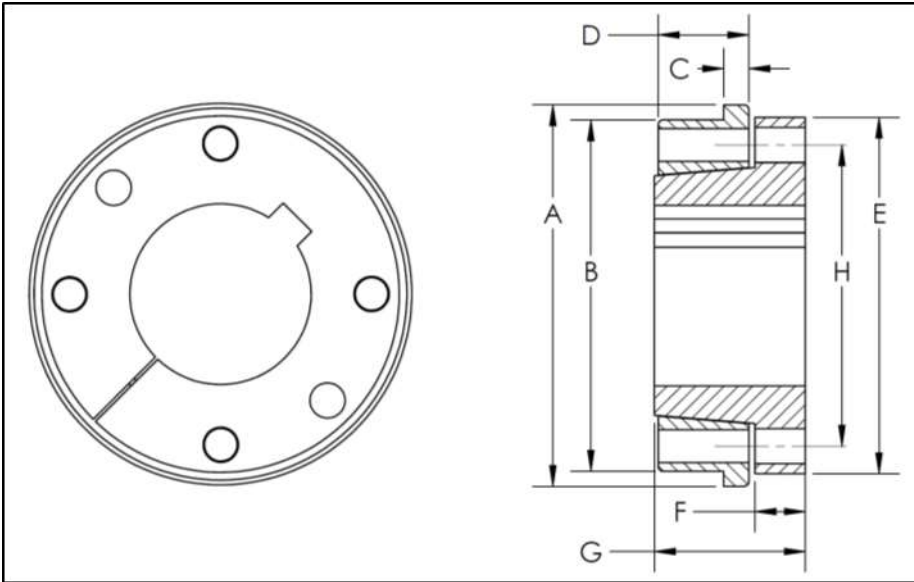

Precision Machined 300 Series Stainless Steel
2" Taper per Foot
Stock Availability
Inch and Metric Bore Sizes
Made in the USA

Hub Bushing	HUB SPECIFICATIONS				BUSHING SPECIFICATIONS								
	A	B	C	D	E	F	G	H	# of Bolts	Bolt Size	Maximum Bolt Torque (in/lbs)	Maximum Bore	
	Flange Dia.	Pilot Dia.	Flange Width	Total Length	Flange Dia.	Flange Width	Total Length	Bolt Circle				inch	mm
XT15	3.250	2.875	0.188	0.625	2.875	0.375	1.125	2.438	4	1/4	75	1-1/2	35
XT20	4.125	3.813	0.250	0.813	3.750	0.469	1.406	3.188	4	5/16	130	2	50
XT25	4.750	4.375	0.313	1.125	4.438	0.625	1.875	3.750	4	3/8	230	2-1/2	65
XT30	6.000	5.750	0.375	1.250	5.313	0.688	2.063	4.563	4	7/16	370	3	75
XT35	6.625	6.344	0.438	1.500	6.313	0.781	2.469	5.438	4	1/2	510	3-1/2	90
XT40	7.625	7.250	0.500	1.750	7.125	0.875	2.818	6.125	4	9/16	680	4	100
XT45	8.375	8.000	0.625	2.125	8.000	0.938	3.313	6.875	4	5/8	1110	4-1/2	110
XT50	10.000	9.563	0.750	2.500	10.125	1.000	3.750	8.313	4	3/4	1530	5	125

Nomenclature

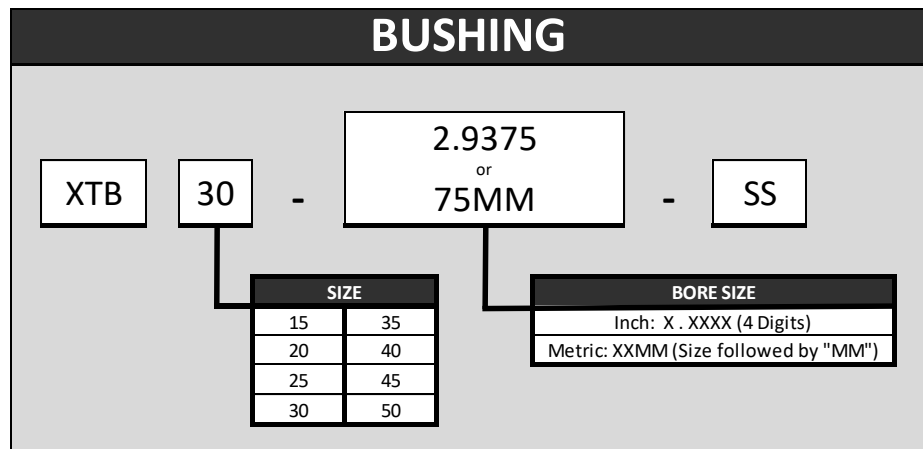
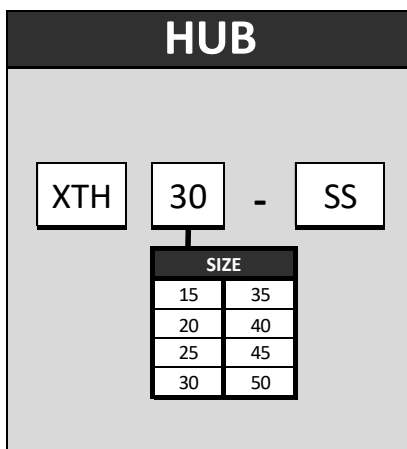

XT® is a registered trademark of Van Gorp Corp.



(989)358-6149

www.pcimfg.com

ACCESSORIES

Stainless Steel Compression Hubs & Bushings HE Style

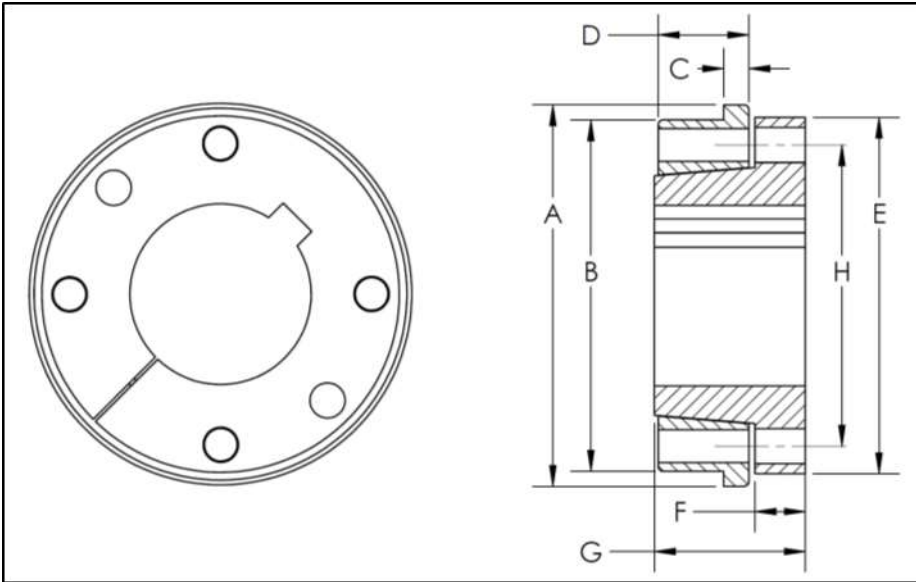

Precision Machined 300 Series Stainless Steel
3" Taper per Foot
Stock Availability
Inch and Metric Bore Sizes
Made in the USA

Hub Bushing	HUB SPECIFICATIONS				BUSHING SPECIFICATIONS								
	A	B	C	D	E	F	G	H	# of Bolts	Bolt Size	Maximum Bolt Torque (in/lbs)	Maximum Bore	
	Flange Dia.	Pilot Dia.	Flange Width	Total Length	Flange Dia.	Flange Width	Total Length	Bolt Circle				inch	mm
HE25	4.700	4.499	0.318	1.140	4.625	0.750	1.805	3.938	4	3/8	230	2-1/2	65
HE30	6.000	5.750	0.380	1.265	5.625	0.875	2.200	4.688	4	1/2	510	3	75
HE35	6.910	6.627	0.505	1.515	6.625	0.875	2.780	5.563	4	9/16	680	3-1/2	90
HE40	8.420	8.000	0.505	1.765	7.500	1.000	2.925	6.313	4	5/8	1110	4	100
HE45	9.000	8.499	0.630	2.140	8.750	1.250	3.200	7.313	6	5/8	1110	4-1/2	110
HE50	10.000	9.562	0.725	2.515	9.625	1.500	3.700	8.000	6	3/4	1530	5	125

Nomenclature

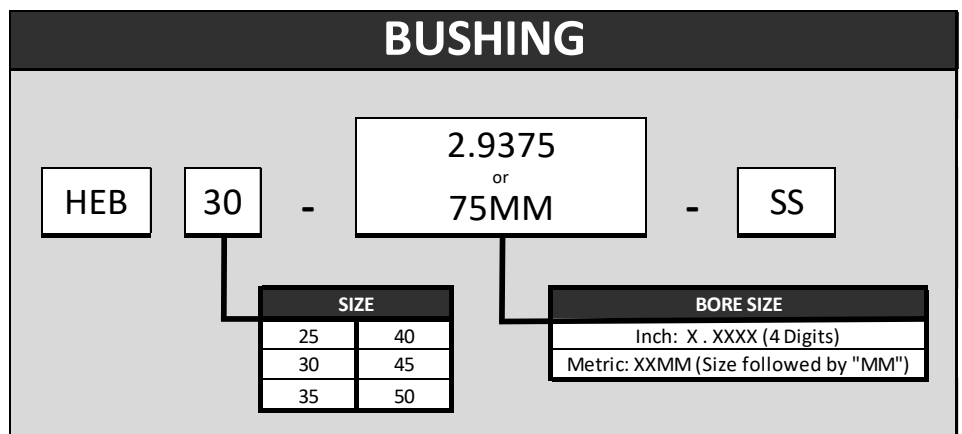
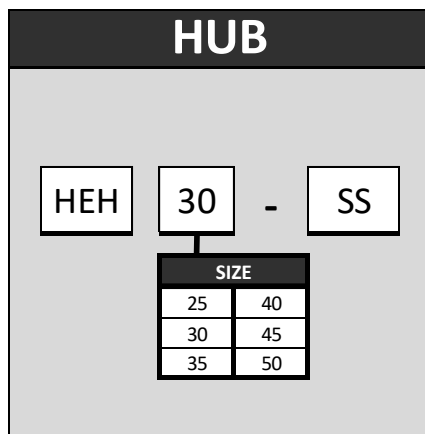

ACCESSORIES

Stainless Steel Compression Hubs & Bushings QD® Style

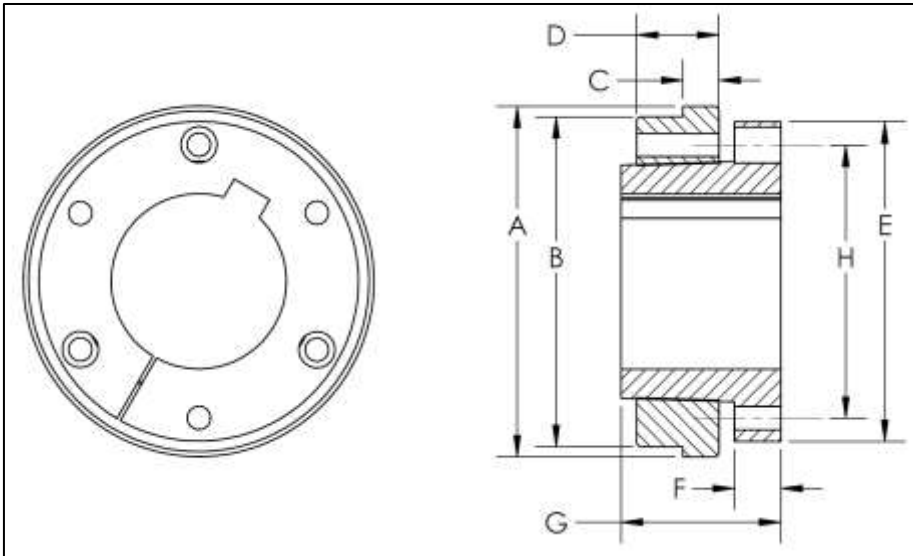

Precision Machined 300 Series Stainless Steel
3/4" Taper per Foot
Stock Availability
Inch and Metric Bore Sizes
Made in the USA

Hub Bushing	HUB SPECIFICATIONS				BUSHING SPECIFICATIONS								
	A	B	C	D	E	F	G	H	# of Bolts	Bolt Size	Maximum Bolt Torque (in/lbs)	Maximum Bore	
	Flange Dia.	Pilot Dia.	Flange Width	Total Length	Flange Dia.	Flange Width	Total Length	Bolt Circle				inch	mm
JA	2.313	2.125	0.375	0.563	2.000	0.313	1.000	1.656	3	10-24	20	1-1/4	25
SH	3.125	2.875	0.500	0.813	2.625	0.438	1.313	2.250	3	1/4	75	1-11/16	35
SDS	3.625	3.375	0.438	0.750	3.125	0.438	1.313	2.688	3	1/4	75	2	40
SK	4.250	4.000	0.438	1.000	3.875	0.563	1.938	3.313	3	5/16	130	2/5/8	55
SF	5.000	4.750	0.438	1.000	4.625	0.625	2.063	3.875	3	3/8	230	2-15/16	60
E	6.250	6.000	0.500	1.125	6.000	0.875	2.750	5.000	3	1/2	510	3-1/2	75
F	7.000	6.750	0.563	1.250	6.625	1.000	3.750	5.625	3	9/16	680	4	90
JS	8.250	8.000	0.625	1.625	7.250	1.000	3.375	6.250	3	5/8	1110	4-1/2	110
MS	9.500	9.250	0.750	2.370	9.000	1.188	4.813	7.875	4	3/4	1530	5-1/2	120

Nomenclature

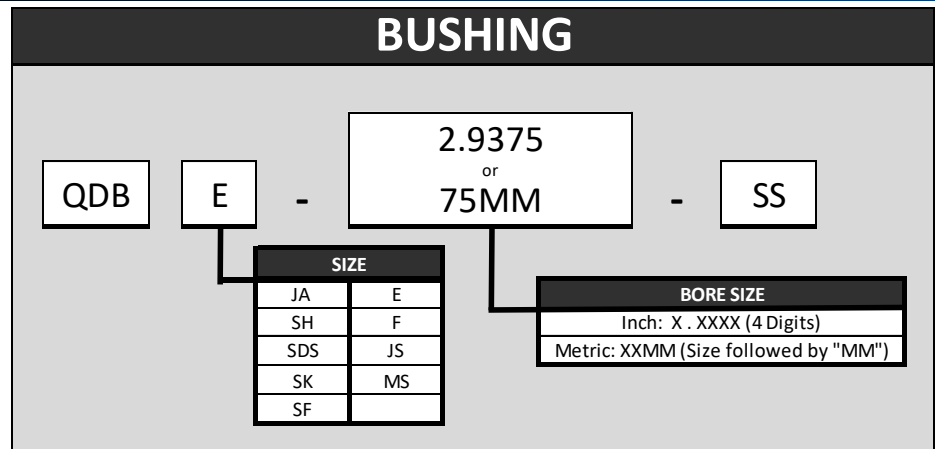
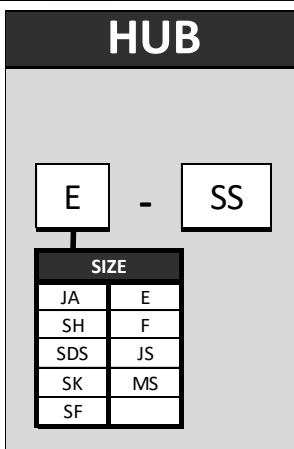

QD® is a registered trademark of Emerson Electric Corp.



(989)358-6149

www.pcimfg.com

ACCESSORIES

Stainless Steel Compression Hubs & Bushings Taper-Lock® Style

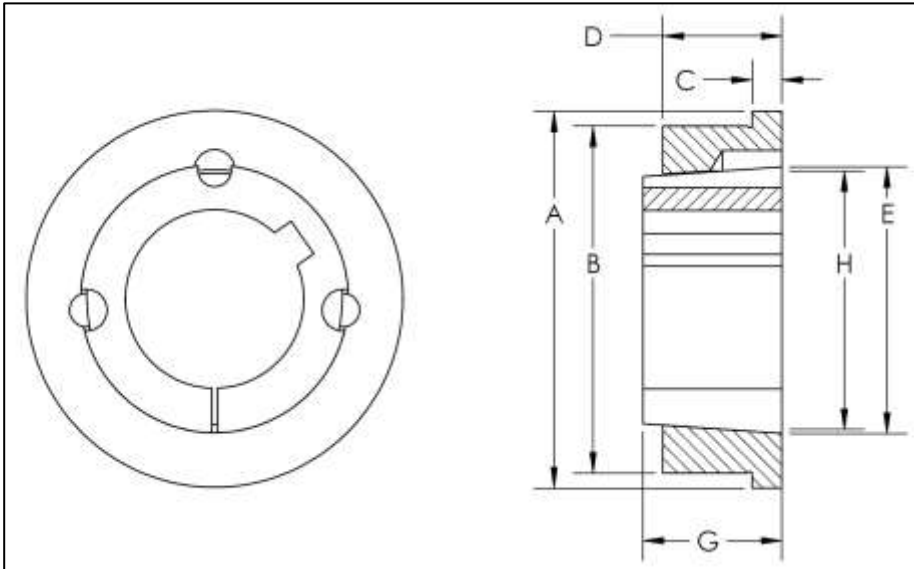

Precision Machined 300 Series Stainless Steel
1-11/16" Taper per Foot
Stock Availability
Inch and Metric Bore Sizes
Made in the USA

Hub Bushing	HUB SPECIFICATIONS				BUSHING SPECIFICATIONS							
	A	B	C	D	E	G	H	# of Bolts	Bolt Size	Maximum Bolt Torque (in/lbs)	Maximum Bore	
	Flange Dia.	Pilot Dia.	Flange Width	Total Length	Bushing Dia.	Total Length	Bolt Circle				inch	mm
1210	2.875	2.500	0.313	0.875	1.875	1.000	1.750	2	3/8	115	1-1/4	30
1610	3.250	2.875	0.313	0.875	2.250	1.000	2.125	2	3/8	115	1-11/16	40
2012	3.750	3.438	0.313	1.000	2.750	1.250	2.625	2	7/16	185	2	45
2517	4.750	4.375	0.375	1.500	3.375	1.750	3.250	2	1/2	255	2-1/2	65
3020	5.500	5.125	0.375	1.625	4.250	2.000	4.000	2	5/8	555	3	75
3535	6.750	6.250	0.500	1.625	5.000	3.500	4.828	3	1/2	700	3-1/2	90
4040	7.750	7.250	0.500	2.125	5.750	4.000	5.548	3	5/8	1110	4	100
4545	8.500	8.000	0.625	2.625	6.375	4.500	6.125	3	3/4	1520	4-1/2	115
5050	9.250	8.750	0.625	2.875	7.000	5.000	6.719	3	7/8	1930	5	125

Nomenclature

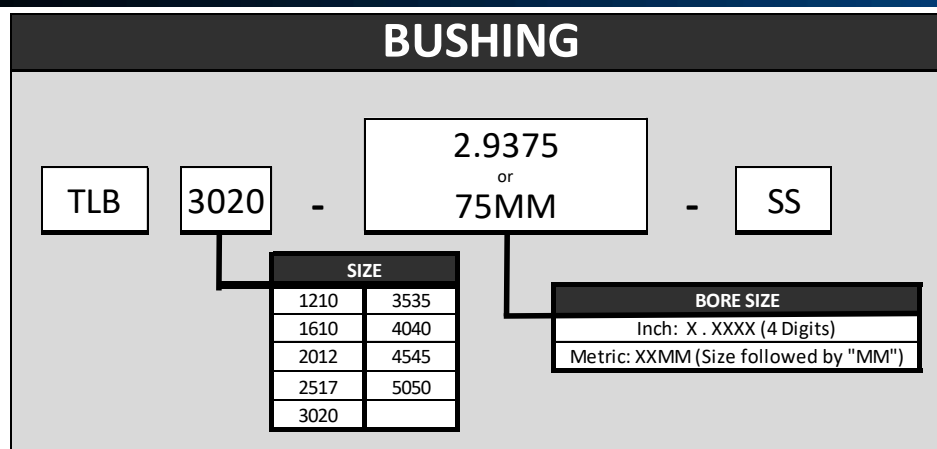
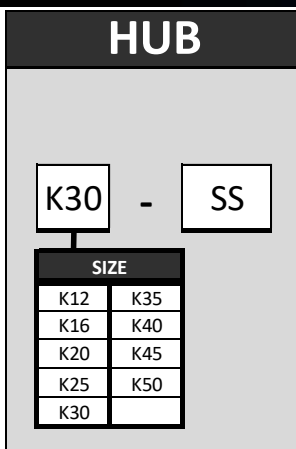

Taper-Lock® is a registered trademark of Reliance Electric



(989)358-6149

www.pcimfg.com

ACCESSORIES

Stainless Steel Compression Hubs & Bushings

Key Sizes – XT® Bushings



Imperial Sized Product (inches)					
	Bore Range		Keyseat Size		Key Stock Size
			Bushings	Axle	F: Full S: Shallow N: None
	min	max			
XT15	5/8	7/8	3/16 X 3/32	3/16 X 3/32	3/16 X 3/16
	15/16	1-1/4	1/4 X 1/8	1/4 X 1/8	1/4 X 1/4
	1-5/16	1-3/8	5/16 X 5/32	5/16 X 5/32	5/16 X 5/16
	1-7/16	1-1/2	3/8 X 1/8	3/8 X 3/16	3/8 X 5/16
XT20	3/4	7/8	3/16 X 3/32	3/16 X 3/32	3/16 X 3/16
	15/16	1-1/4	1/4 X 1/8	1/4 X 1/8	1/4 X 1/4
	1-5/16	1-3/8	5/16 X 5/32	5/16 X 5/32	5/16 X 5/16
	1-7/16	1-3/4	3/8 X 3/16	3/8 X 3/16	3/8 X 3/8
	1-13/16	2	1/2 X 3/16	1/2 X 1/4	1/2 X 7/16
XT25	1	1-1/4	1/4 X 1/8	1/4 X 1/8	1/4 X 1/4
	1-5/16	1-3/8	5/16 X 5/32	5/16 X 5/32	5/16 X 5/16
	1-7/16	1-3/4	3/8 X 3/16	3/8 X 3/16	3/8 X 3/8
	1-13/16	2-1/4	1/2 X 1/4	1/2 X 1/4	1/2 X 1/2
	2-5/16	2-1/2	5/8 X 1/8	5/8 X 5/16	5/8 X 7/16
XT30	1-7/16	1-3/4	3/8 X 3/16	3/8 X 3/16	3/8 X 3/8
	1-13/16	2-1/4	1/2 X 1/4	1/2 X 1/4	1/2 X 1/2
	2-5/16	2-3/4	5/8 X 5/16	5/8 X 5/16	5/8 X 5/8
	2-13/16	3	3/4 X 3/16	3/4 X 3/8	3/4 X 9/16
XT35	1-15/16	2-1/4	1/2 X 1/4	1/2 X 1/4	1/2 X 1/2
	2-5/16	2-3/4	5/8 X 5/16	5/8 X 5/16	5/8 X 5/8
	2-13/16	3-1/4	3/4 X 3/8	3/4 X 3/8	3/4 X 3/4
	3-5/16	3-3/8	7/8 X 7/16	7/8 X 7/16	7/8 X 7/8
XT40	2-7/16	2-3/4	5/8 X 5/16	5/8 X 5/16	5/8 X 5/8
	2-13/16	3-1/4	3/4 X 3/8	3/4 X 3/8	3/4 X 3/4
	3-5/16	3-3/4	7/8 X 7/16	7/8 X 7/16	7/8 X 7/8
	3-13/16		1 X 1/2	1 X 1/2	1 X 1
	3-7/8	4	1 X 3/8	1 X 1/2	1 X 7/8
XT45	2-7/16	2-3/4	5/8 X 5/16	5/8 X 5/16	5/8 X 5/8
	2-13/16	3-1/4	3/4 X 3/8	3/4 X 3/8	3/4 X 3/4
	3-5/16	3-3/4	7/8 X 7/16	7/8 X 7/16	7/8 X 7/8
	3-13/16	4-5/16	1 X 1/2	1 X 1/2	1 X 1
	4-3/8	4-1/2	1 X 3/8	1 X 1/2	1 X 7/8
XT50	2-15/16	3-1/4	3/4 X 3/8	3/4 X 3/8	3/4 X 3/4
	3-5/16	3-3/4	7/8 X 7/16	7/8 X 7/16	7/8 X 7/8
	3-13/16	4-1/2	1 X 1/2	1 X 1/2	1 X 1
	4-9/16	5	1-1/4 X 5/8	1-1/4 X 5/8	1-1/4 X 1-1/4

Metric Sized Product (mm)					
	Bore Range		Keyseat Size		Key Stock Size
			Bushings	Axle	
	min	max			
XT15	20		6 X 2.8	6 X 3.5	6 X 6
	25	30	8 X 3.3	8 X 4	8 X 7
	35		10 X 3.3	10 X 5	10 X 8
XT20	20		6 X 2.8	6 X 3.5	6 X 6
	25	30	8 X 3.3	8 X 4	8 X 7
	35		10 X 3.3	10 X 5	10 X 8
	40		12 X 3.3	12 X 5	12 X 8
	45	50	14 X 3.8	14 X 5.5	14 X 9
XT25	25	30	8 X 3.3	8 X 4	8 X 7
	35		10 X 3.3	10 X 5	10 X 8
	40		12 X 3.3	12 X 5	12 X 8
	45	50	14 X 3.8	14 X 5.5	14 X 9
	55		16 X 4.3	16 X 6	16 X 10
	60	65	18 X 4.4	18 X 7	18 X 11
XT30	35		10 X 3.3	10 X 5	10 X 8
	40		12 X 3.3	12 X 5	12 X 8
	45	50	14 X 3.8	14 X 5.5	14 X 9
	55		16 X 4.3	16 X 6	16 X 10
	60	65	18 X 4.4	18 X 7	18 X 11
	70	75	20 X 4.9	20 X 7.5	20 X 12
XT35	50		14 X 3.8	14 X 5.5	14 X 9
	55		16 X 4.3	16 X 6	16 X 10
	60	65	18 X 4.4	18 X 7	18 X 11
	70	75	20 X 4.9	20 X 7.5	20 X 12
	80	85	22 X 5.4	22 X 9	22 X 14
XT40	90		25 X 5.4	25 X 9	25 X 14
	60	65	18 X 4.4	18 X 7	18 X 11
	70	75	20 X 4.9	20 X 7.5	20 X 12
	80	85	22 X 5.4	22 X 9	22 X 14
	90	95	25 X 5.4	25 X 9	25 X 14
XT45	100		28 X 6.4	28 X 10	28 X 16
	80	85	22 X 5.4	22 X 9	22 X 14
	90	95	25 X 5.4	25 X 9	25 X 14
	100	110	28 X 6.4	28 X 10	28 X 16
XT50	80	85	22 X 5.4	22 X 9	22 X 14
	90	95	25 X 5.4	25 X 9	25 X 14
	100	110	28 X 6.4	28 X 10	28 X 16
	115	125	32 X 7.4	32 X 11	32 X 18

ACCESSORIES

Stainless Steel Compression Hubs & Bushings Key Sizes – HE Bushings



Imperial Sized Product (inches)					
	Bore Range		Keyseat Size		Key Stock Size
			Bushings	Axle	F: Full S: Shallow N: None
	min	max			
HE25	1	1-1/4	1/4 X 1/8	1/4 X 1/8	1/4 X 1/4
	1-5/16	1-3/8	5/16 X 5/32	5/16 X 5/32	5/16 X 5/16
	1-7/16	1-3/4	3/8 X 3/16	3/8 X 3/16	3/8 X 3/8
	1-13/16	2-1/4	1/2 X 1/4	1/2 X 1/4	1/2 X 1/2
	2-5/16	2-1/2	5/8 X 3/16	5/8 X 5/16	5/8 X 1/2
HE30	1-7/16	1-3/4	3/8 X 3/16	3/8 X 3/16	3/8 X 3/8
	1-13/16	2-1/4	1/2 X 1/4	1/2 X 1/4	1/2 X 1/2
	2-5/16	2-3/4	5/8 X 5/16	5/8 X 5/16	5/8 X 5/8
HE35	2-13/16	3	3/4 X 1/8	3/4 X 3/8	3/4 X 1/2
	1-15/16	2-1/4	1/2 X 1/4	1/2 X 1/4	1/2 X 1/2
	2-5/16	2-3/4	5/8 X 5/16	5/8 X 5/16	5/8 X 5/8
	2-13/16	3-1/4	3/4 X 3/8	3/4 X 3/8	3/4 X 3/4
	3-5/16	3-5/16	7/8 X 7/16	7/8 X 7/16	7/8 X 7/8
HE40	3-3/8	3-1/2	7/8 X 3/16	7/8 X 7/16	7/8 X 5/8
	2-7/16	2-3/4	5/8 X 5/16	5/8 X 5/16	5/8 X 5/8
	2-13/16	3-1/4	3/4 X 3/8	3/4 X 3/8	3/4 X 3/4
	3-5/16	3-3/4	7/8 X 7/16	7/8 X 7/16	7/8 X 7/8
	3-13/16		1 X 1/2	1 X 1/2	1 X 1
HE45	3-7/8	4	1 X 1/4	1 X 1/2	1 X 3/4
	2-7/16	2-3/4	5/8 X 5/16	5/8 X 5/16	5/8 X 5/8
	2-13/16	3-1/4	3/4 X 3/8	3/4 X 3/8	3/4 X 3/4
	3-5/16	3-3/4	7/8 X 7/16	7/8 X 7/16	7/8 X 7/8
	3-13/16	4-1/8	1 X 1/2	1 X 1/2	1 X 1
HE50	4-3/16	4-1/2	1 X 1/4	1 X 1/2	1 X 3/4
	2-15/16	3-1/4	3/4 X 3/8	3/4 X 3/8	3/4 X 3/4
	3-5/16	3-3/4	7/8 X 7/16	7/8 X 7/16	7/8 X 7/8
	3-13/16	4-1/2	1 X 1/2	1 X 1/2	1 X 1
	4-9/16	4-3/4	1-1/4 X 5/8	1-1/4 X 5/8	1-1/4 X 1-1/4
	4-13/16	5	1-1/4 X 1/4	1-1/4 X 5/8	1-1/4 X 7/8

Metric Sized Product (mm)					
	Bore Range		Keyseat Size		Key Stock Size
			Bushings	Axle	
	min	max			
HE25	25	30	8 X 3.3	8 X 4	8 X 7
	35		10 X 3.3	10 X 5	10 X 8
	40		12 X 3.3	12 X 5	12 X 8
	45	50	14 X 3.8	14 X 5.5	14 X 9
	55		16 X 4.3	16 X 6	16 X 10
HE30	60	65	18 X 4.4	18 X 7	18 X 11
	35		10 X 3.3	10 X 5	10 X 8
	40		12 X 3.3	12 X 5	12 X 8
	45	50	14 X 3.8	14 X 5.5	14 X 9
	55		16 X 4.3	16 X 6	16 X 10
HE35	60	65	18 X 4.4	18 X 7	18 X 11
	70	75	20 X 4.9	20 X 7.5	20 X 12
	50		14 X 3.8	14 X 5.5	14 X 9
	55		16 X 4.3	16 X 6	16 X 10
	60	65	18 X 4.4	18 X 7	18 X 11
HE40	70	75	20 X 4.9	20 X 7.5	20 X 12
	80	85	22 X 5.4	22 X 9	22 X 14
	90		25 X 5.4	25 X 9	25 X 14
	60	65	18 X 4.4	18 X 7	18 X 11
	70	75	20 X 4.9	20 X 7.5	20 X 12
HE45	80	85	22 X 5.4	22 X 9	22 X 14
	90	95	25 X 5.4	25 X 9	25 X 14
	100		28 X 6.4	28 X 10	28 X 16
	80	85	22 X 5.4	22 X 9	22 X 14
	90	95	25 X 5.4	25 X 9	25 X 14
HE50	100	110	28 X 6.4	28 X 10	28 X 16
	115	125	32 X 7.4	32 X 11	32 X 18
	80	85	22 X 5.4	22 X 9	22 X 14
	90	95	25 X 5.4	25 X 9	25 X 14
	100	110	28 X 6.4	28 X 10	28 X 16

ACCESSORIES

Stainless Steel Compression Hubs & Bushings

Key Sizes – QD® Bushings



Imperial Sized Product (inches)						
	Bore Range		Keyseat Size		Key Stock Size	
			Bushings	Axle	F: Full S: Shallow N: None	
	min	max				
JA	1/2	9/16	1/8 X 1/16	1/8 X 1/16	1/8 X 1/8	F
	5/8	7/8	3/16 X 3/32	3/16 X 3/32	3/16 X 3/16	
	15/16	1	1/4 X 1/8	1/4 X 1/8	1/4 X 1/4	S
	1-1/16	1-3/16	1/4 X 1/16	1/4 X 1/8	1/4 X 3/16	
	1-1/4		-	-	-	
SH	5/8	7/8	3/16 X 3/32	3/16 X 3/32	3/16 X 3/16	F
	15/16	1-1/4	1/4 X 1/8	1/4 X 1/8	1/4 X 1/4	
	1-5/16	1-3/8	5/16 X 5/32	5/16 X 5/32	5/16 X 5/16	S
	1-7/16	1-5/8	3/8 X 1/16	3/8 X 3/16	3/8 X 1/4	
	1-11/16		-	-	-	
SDS	3/4	7/8	3/16 X 3/32	3/16 X 3/32	3/16 X 3/16	F
	15/16	1-1/4	1/4 X 1/8	1/4 X 1/8	1/4 X 1/4	
	1-5/16	1-3/8	5/16 X 5/32	5/16 X 5/32	5/16 X 5/16	S
	1-7/16	1-5/8	3/8 X 3/16	3/8 X 3/16	3/8 X 3/8	
	1-11/16	1-3/4	3/8 X 1/8	3/8 X 3/16	3/8 X 5/16	
	1-13/16	1-15/16	1/2 X 1/16	1/2 X 1/4	1/2 X 5/16	N
	2		-	-	-	
SK	1	1-1/4	1/4 X 1/8	1/4 X 1/8	1/4 X 1/4	F
	1-5/16	1-3/8	5/16 X 5/32	5/16 X 5/32	5/16 X 5/16	
	1-7/16	1-3/4	3/8 X 3/16	3/8 X 3/16	3/8 X 3/8	S
	1-13/16	2-1/8	1/2 X 1/4	1/2 X 1/4	1/2 X 1/2	
	2-3/16	2-1/4	1/2 X 1/8	1/2 X 1/4	1/2 X 3/8	
	2-5/16	2-1/2	5/8 X 1/16	5/8 X 5/16	5/8 X 3/8	N
	2-5/8		-	-	-	
SF	1	1-1/4	1/4 X 1/8	1/4 X 1/8	1/4 X 1/4	F
	1-5/16	1-3/8	5/16 X 5/32	5/16 X 5/32	5/16 X 5/16	
	1-7/16	1-3/4	3/8 X 3/16	3/8 X 3/16	3/8 X 3/8	S
	1-13/16	2-1/4	1/2 X 1/4	1/2 X 1/4	1/2 X 1/2	
	2-5/16		5/8 X 5/16	5/8 X 5/16	5/8 X 5/8	
	2-3/8	2-1/2	5/8 X 3/16	5/8 X 5/16	5/8 X 1/2	N
	2-9/16	2-3/4	5/8 X 1/16	5/8 X 5/16	5/8 X 3/8	
	2-13/16		3/4 X 1/8	3/4 X 3/8	3/4 X 1/2	
	2-7/8	2-15/16	3/4 X 1/32	3/4 X 3/8	3/4 X 13/32	
E	1-7/16	1-3/4	3/8 X 3/16	3/8 X 3/16	3/8 X 3/8	F
	1-13/16	2-1/4	1/2 X 1/4	1/2 X 1/4	1/2 X 1/2	
	2-5/16	2-3/4	5/8 X 5/16	5/8 X 5/16	5/8 X 5/8	S
	2-13/16	2-7/8	3/4 X 3/8	3/4 X 3/8	3/4 X 3/4	
	2-15/16	3-1/4	3/4 X 1/8	3/4 X 3/8	3/4 X 1/2	
	3-5/16		7/8 X 1/8	7/8 X 7/16	7/8 X 9/16	N
	3-3/8	3-1/2	7/8 X 1/16	7/8 X 7/16	7/8 X 1/2	
F	1-15/16	2-1/4	1/2 X 1/4	1/2 X 1/4	1/2 X 1/2	F
	2-5/16	2-3/4	5/8 X 5/16	5/8 X 5/16	5/8 X 5/8	
	2-13/16	3-1/4	3/4 X 3/8	3/4 X 3/8	3/4 X 3/4	S
	3-5/16	3-3/4	7/8 X 3/16	7/8 X 7/16	7/8 X 5/8	
	3-7/8	3-15/16	1 X 1/8	1 X 1/2	1 X 5/8	
4		-	-	-		
JS	2-15/16	3-1/4	3/4 X 3/8	3/4 X 3/8	3/4 X 3/4	F
	3-5/16	3-3/4	7/8 X 7/16	7/8 X 7/16	7/8 X 7/8	
	3-13/16		1 X 1/2	1 X 1/2	1 X 1	S
	3-7/8	4	1 X 1/4	1 X 1/2	1 X 3/4	
	4-1/16	4-1/2	1 X 1/8	1 X 1/2	1 X 5/8	
MS	2-15/16	3-1/4	3/4 X 3/8	3/4 X 3/8	3/4 X 3/4	F
	3-5/16	3-3/4	7/8 X 7/16	7/8 X 7/16	7/8 X 7/8	
	3-13/16	4-1/2	1 X 1/2	1 X 1/2	1 X 1	S
	4-9/16	4-3/4	1-1/4 X 5/8	1-1/4 X 5/8	1-1/4 X 1-1/4	
	4-13/16	5-1/4	1-1/4 X 3/8	1-1/4 X 5/8	1-1/4 X 1	
5-5/16	5-1/2	1-1/4 X 1/4	1-1/4 X 5/8	1-1/4 X 7/8		

Metric Sized Product (mm)					
	Bore Range		Keyseat Size		Key Stock Size
			Bushings	Axle	
	min	max			
JA	20		6 X 2.8	6 X 3.5	6 X 6
	25		8 X 3.3	8 X 4	8 X 7
SH	25	30	8 X 3.3	8 X 4	8 X 7
	35		10 X 3.3	10 X 5	10 X 8
SDS	25	30	8 X 3.3	8 X 4	8 X 7
	35		10 X 3.3	10 X 5	10 X 8
	40		12 X 3.3	12 X 5	12 X 8
SK	25	30	8 X 3.3	8 X 4	8 X 7
	35		10 X 3.3	10 X 5	10 X 8
	40		12 X 3.3	12 X 5	12 X 8
	45	50	14 X 3.8	14 X 5.5	14 X 9
	55		16 X 4.3	16 X 6	16 X 10
SF	30		8 X 3.3	8 X 4	8 X 7
	35		10 X 3.3	10 X 5	10 X 8
	40		12 X 3.3	12 X 5	12 X 8
	45	50	14 X 3.8	14 X 5.5	14 X 9
	55		16 X 4.3	16 X 6	16 X 10
	60		18 X 4.4	18 X 7	18 X 11
E	35		10 X 3.3	10 X 5	10 X 8
	40		12 X 3.3	12 X 5	12 X 8
	45	50	14 X 3.8	14 X 5.5	14 X 9
	55		16 X 4.3	16 X 6	16 X 10
	60	65	18 X 4.4	18 X 7	18 X 11
	70	75	20 X 4.9	20 X 7.5	20 X 12
F	45	50	14 X 3.8	14 X 5.5	14 X 9
	55		16 X 4.3	16 X 6	16 X 10
	60	65	18 X 4.4	18 X 7	18 X 11
	70	75	20 X 4.9	20 X 7.5	20 X 12
	80	85	22 X 5.4	22 X 9	22 X 14
	90		25 X 5.4	25 X 9	25 X 14
JS	60	65	18 X 4.4	18 X 7	18 X 11
	70	75	20 X 4.9	20 X 7.5	20 X 12
	80	85	22 X 5.4	22 X 9	22 X 14
	90	95	25 X 5.4	25 X 9	25 X 14
MS	100	110	28 X 6.4	28 X 10	28 X 16
	80	85	22 X 5.4	22 X 9	22 X 14
	90	95	25 X 5.4	25 X 9	25 X 14
	100	110	28 X 6.4	28 X 10	28 X 16
	115	120	32 X 7.4	32 X 11	32 X 18

ACCESSORIES

Stainless Steel Compression Hubs & Bushings Key Sizes – Taper-Lock® Bushings



Imperial Sized Product (inches)					
	Bore Range		Keyseat Size		Key Stock Size
			Bushings	Axle	F: Full S: Shallow N: None
	min	max			
1210	1/2	9/16	1/8 X 1/16	1/8 X 1/16	1/8 X 1/8
	5/8	7/8	3/16 X 3/32	3/16 X 3/32	3/16 X 3/16
	15/16	1-1/4	1/4 X 1/8	1/4 X 1/8	1/4 X 1/4
1610	1/2	9/16	1/8 X 1-1/16	1/8 X 1-1/16	1/8 X 1/8
	5/8	7/8	3/16 X 3/32	3/16 X 3/32	3/16 X 3/16
	15/16	1-1/4	1/4 X 1/8	1/4 X 1/8	1/4 X 1/4
	1-5/16	1-3/8	5/16 X 5/32	5/16 X 5/32	5/16 X 5/16
	1-7/16	1-1/2	3/8 X 3/16	3/8 X 3/16	3/8 X 3/8
	1-9/16	1-11/16	3/8 X 1/8	3/8 X 3/16	3/8 X 5/16
2012	3/4	7/8	3/16 X 3/32	3/16 X 3/32	3/16 X 3/16
	15/16	1-1/4	1/4 X 1/8	1/4 X 1/8	1/4 X 1/4
	1-5/16	1-3/8	5/16 X 5/32	5/16 X 5/32	5/16 X 5/16
	1-7/16	1-3/4	3/8 X 3/16	3/8 X 3/16	3/8 X 3/8
	1-13/16	1-7/8	1/2 X 1/4	1/2 X 1/4	1/2 X 1/2
	1-15/16	2	1/2 X 3/16	1/2 X 1/4	1/2 X 7/16
2517	1	1-1/4	1/4 X 1/8	1/4 X 1/8	1/4 X 1/4
	1-5/16	1-3/8	5/16 X 5/32	5/16 X 5/32	5/16 X 5/16
	1-7/16	1-3/4	3/8 X 3/16	3/8 X 3/16	3/8 X 3/8
	1-13/16	2-1/4	1/2 X 1/4	1/2 X 1/4	1/2 X 1/2
	2-5/16	2-1/2	5/8 X 3/16	5/8 X 5/16	5/8 X 1/2
3020	1-7/16	1-3/4	3/8 X 3/16	3/8 X 3/16	3/8 X 3/8
	1-13/16	2-1/4	1/2 X 1/4	1/2 X 1/4	1/2 X 1/2
	2-5/16	2-3/4	5/8 X 5/16	5/8 X 5/16	5/8 X 5/8
	2-13/16	3	3/4 X 1/4	3/4 X 3/8	3/4 X 5/8
3535	1-15/16	2-1/4	1/2 X 1/4	1/2 X 1/4	1/2 X 1/2
	2-5/16	2-3/4	5/8 X 5/16	5/8 X 5/16	5/8 X 5/8
	2-13/16	3-1/4	3/4 X 3/8	3/4 X 3/8	3/4 X 3/4
	3-5/16		7/8 X 1/8	7/8 X 7/16	7/8 X 9/16
4040	3-3/8	3-1/2	7/8 X 3/16	7/8 X 7/16	7/8 X 5/8
	2-7/16	2-3/4	5/8 X 5/16	5/8 X 5/16	5/8 X 5/8
	2-13/16	3-1/4	3/4 X 3/8	3/4 X 3/8	3/4 X 3/4
	3-5/16	3-3/4	7/8 X 7/16	7/8 X 7/16	7/8 X 7/8
4545	3-13/16	4	1 X 1/4	1 X 1/2	1 X 3/4
	3-7/16	3-3/4	7/8 X 7/16	7/8 X 7/16	7/8 X 7/8
	3-13/16	4-1/4	1 X 1/2	1 X 1/2	1 X 1
5050	4-5/16	4-1/2	1 X 1/4	1 X 1/2	1 X 3/4
	3-5/8	4-1/2	1 X 1/2	1 X 1/2	1 X 1
	4-9/16	5	1-1/4 X 1/4	1-1/4 X 5/8	1-1/4 X 7/8

Metric Sized Product (mm)					
	Bore Range		Keyseat Size		Key Stock Size
			Bushings	Axle	
	min	max			
1210	20		6 X 2.8	6 X 3.5	6 X 6
	25	30	8 X 3.3	8 X 4	8 X 7
1610	20		6 X 2.8	6 X 3.5	6 X 6
	25	30	8 X 3.3	8 X 4	8 X 7
	35		10 X 3.3	10 X 5	10 X 8
	40		12 X 3.3	12 X 5	12 X 8
2012	25	30	8 X 3.3	8 X 4	8 X 7
	35		10 X 3.3	10 X 5	10 X 8
	40		12 X 3.3	12 X 5	12 X 8
	45		14 X 3.8	14 X 5.5	14 X 9
2517	25	30	8 X 3.3	8 X 4	8 X 7
	35		10 X 3.3	10 X 5	10 X 8
	40		12 X 3.3	12 X 5	12 X 8
	45	50	14 X 3.8	14 X 5.5	14 X 9
	55		16 X 4.3	16 X 6	16 X 10
	60	65	18 X 4.4	18 X 7	18 X 11
3020	50		14 X 3.8	14 X 5.5	14 X 9
	55		16 X 4.3	16 X 6	16 X 10
	60	65	18 X 4.4	18 X 7	18 X 11
	70	75	20 X 4.9	20 X 7.5	20 X 12
3535	50		14 X 3.8	14 X 5.5	14 X 9
	55		16 X 4.3	16 X 6	16 X 10
	60	65	18 X 4.4	18 X 7	18 X 11
	70	75	20 X 4.9	20 X 7.5	20 X 12
	80	85	22 X 5.4	22 X 9	22 X 14
4040	90		25 X 5.4	25 X 9	25 X 14
	60	65	18 X 4.4	18 X 7	18 X 11
	70	75	20 X 4.9	20 X 7.5	20 X 12
	80	85	22 X 5.4	22 X 9	22 X 14
	90	95	25 X 5.4	25 X 9	25 X 14
4545	100		28 X 6.4	28 X 10	28 X 16
	80	85	22 X 5.4	22 X 9	22 X 14
	90	95	25 X 5.4	25 X 9	25 X 14
	100	110	28 X 6.4	28 X 10	28 X 16
5050	115		32 X 7.4	32 X 11	32 X 18
	80	85	22 X 5.4	22 X 9	22 X 14
	90	95	25 X 5.4	25 X 9	25 X 14
	100	110	28 X 6.4	28 X 10	28 X 16
	115	125	32 X 7.4	32 X 11	32 X 18

ACCESSORIES

XT® Hub Selection



HUB SELECTION

When choosing a hub and bushing system, it is important to understand the different design features and the effects they have on conveyor pulley applications. Consider a design that minimizes end disk pre-stressing, grips the shaft firmly, is easily removed, and is not adversely affected by the bending moments on the pulley shaft.

XT® HUBS AND BUSHINGS

The XT® Hub and Bushing system was specifically designed for use in conveyor pulleys with two hubs. The XT® design has a steep taper angle, 2" taper per foot, which minimizes end disk deflection or pre-stressing that occurs when bushings are installed. The reduction in end disk pre-stressing reduces the likelihood of end disk fatigue. The steep taper angle will reduce the clamping pressure on the shaft, but the XT® design compensates by increasing the number and size of the bolts used to install the bushing. The taper angle of the XT® design is self-locking, which alleviates bolt-breakage experienced on bushings with a taper angle greater than 2" taper per foot. The holes used to install and remove the bushing are spaced equally around the bushing split and keyway. Upon installation, this balances the load required at each bolt location, which provides consistent contact pressure on the shaft. During removal, the equally spaced jack-screws eliminate the chance of bushing breakage. The steep taper angle requires little force to remove the bushing, further reducing the chance of

	XT® STYLE DRUM PULLEY						
	A	B	C	D	E	F	G
XT15	0.750	1.125	0.437	0.594	1.437	0.625	1.250
XT20	0.625	1.406	0.844	0.422	1.469	0.812	1.219
XT25	0.500	1.875	1.500	0.266	1.562	1.125	1.250
XT30	0.625	2.062	1.156	0.344	1.812	1.250	1.437
XT35	0.625	2.469	1.437	0.312	2.031	1.500	1.594
XT40	0.937	2.812	1.437	0.578	2.500	1.750	2.000
XT45	0.937	3.312	1.719	0.547	2.750	2.125	2.125
XT50	0.937	3.750	2.031	0.469	2.937	2.500	2.187
XT60	0.937	4.125	2.125	0.391	3.125	2.750	2.313
XT70	1.125	4.687	2.500	0.516	3.625	3.125	2.688
XT80	1.125	5.125	3.062	0.437	3.812	3.437	2.812
XT100	1.125	6.187	3.062	0.437	4.312	4.125	3.187
XT120	1.125	7.062	3.062	0.437	4.687	4.812	3.375

	XT® STYLE WING PULLEY						
	A	B	C	D	E	F	G
XT15	1.562	1.125	-	1.313	2.250	0.625	2.063
XT20	0.750	1.406	0.875	0.438	1.594	0.813	1.344
XT25	1.187	1.875	1.000	0.813	2.250	1.125	1.938
XT30	1.062	2.062	0.750	0.625	2.249	1.250	1.874
XT35	1.812	2.469	0.250	1.313	2.219	1.500	2.781
XT40	1.687	2.812	0.687	1.125	3.249	1.750	2.749
XT45	1.437	3.312	1.250	0.813	3.249	2.125	2.624
XT50	2.000	3.750	1.000	1.250	4.000	2.500	3.250
XT60	0.937	4.125	2.125	0.063	3.125	2.750	3.313
XT70	1.125	4.687	2.500	0.250	3.750	3.125	2.813
XT80	1.125	5.125	3.062	0.125	3.938	3.438	2.938
XT100	1.125	6.187	3.062	0.125	4.438	4.125	3.313
XT120	1.125	7.062	3.062	0.125	4.813	4.813	3.500

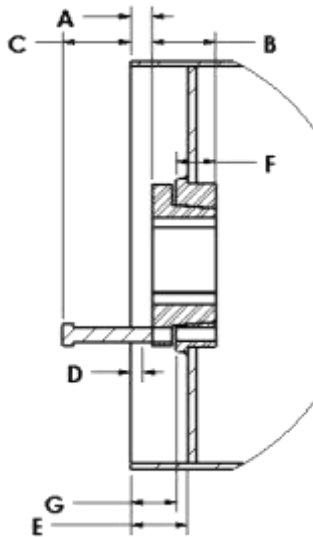

XT® DRUM PULLEY

*C: Space required to remove bushing using jackscrews with short hex key or open end wrench.

HUB SIZING

To select a hub size, choose the smallest hub that will allow the shaft size determined per ANSI/CEMA B105.1-1992. Torsional loading and shallow keyways may also affect hub sizing.

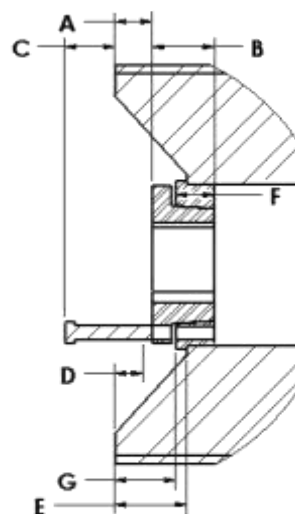

XT® WING PULLEY

HUB SELECTION

When choosing a hub and bushing system, it is important to understand the different design features and the effects they have on conveyor pulley applications. Consider a design that minimizes end disk pre-stressing, grips the shaft firmly, is easily removed, and is not adversely affected by the bending moments on the pulley shaft.

HE HUBS AND BUSHINGS

The HE Hub and Bushing system was specifically designed for use in conveyor pulleys with two hubs. The HE design has a very steep taper angle, 3" taper per foot, which minimizes end disk deflection or pre-stressing that occurs when bushings are installed. The reduction in end disk pre-stressing reduces the likelihood of end disk fatigue. The extra steep taper angle is on the edge of being self-locking and increases the likelihood of bolt breakage. Because of this, grade 8 bolts are standard on PCI's HE bushings, and the number of bolts increases from 4 to 6 on HE45 and larger hubs. The holes used to install and remove the bushing are spaced equally around the bushing split and keyway. Upon installation, this balances the load required at each bolt location, which provides consistent contact pressure on the shaft. During removal, the equally spaced jack-screws eliminate the chance of bushing breakage. The steep taper angle requires little force to remove the bushing, further reducing the chance of bushing breakage.

	HE STYLE DRUM PULLEY						
	A	B	C	D	E	F	G
HE25	0.593	1.805	1.861	0.325	1.818	1.140	1.500
HE30	0.658	2.200	2.147	0.294	2.130	1.265	1.750
HE35	0.719	2.780	2.594	0.344	2.380	1.515	1.875
HE40	0.844	2.925	2.373	0.441	2.630	1.765	2.125
HE45	0.903	3.200	3.182	0.500	3.068	2.140	2.438
HE50	0.937	3.700	3.921	0.454	3.475	2.515	2.750
HE60	0.937	3.940	4.376	0.374	3.755	2.765	3.000

	HE STYLE WING PULLEY						
	A	B	C	D	E	F	G
HE25	1.093	1.805	2.361	0.825	2.318	1.140	2.000
HE30	1.033	2.200	2.522	0.669	2.505	1.265	2.125
HE35	1.625	2.780	3.500	1.250	3.286	1.515	2.781
HE40	1.657	2.925	3.186	1.254	3.443	1.765	2.938
HE45	1.465	3.200	3.744	1.062	3.630	2.140	3.000
HE50	1.937	3.700	4.921	1.454	4.475	2.515	3.750
HE60	1.187	3.940	4.626	0.624	4.005	2.765	3.250

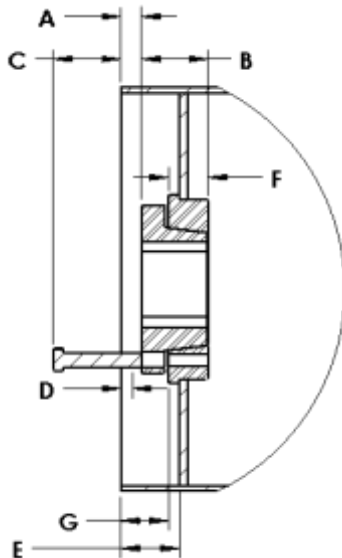

XT® DRUM PULLEY

*C: Space required to remove bushing using jackscrews with short hex key or open end wrench.

HUB SIZING

To select a hub size, choose the smallest hub that will allow the shaft size determined per ANSI/CEMA B105.1-1992. Torsional loading and shallow keyways may also affect hub sizing.

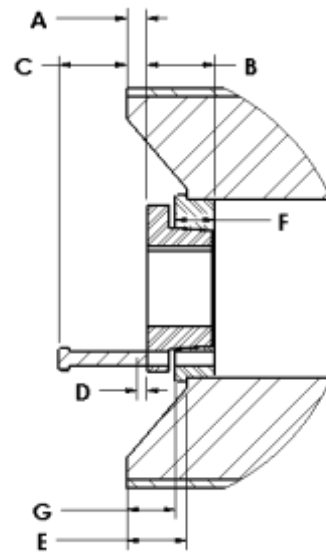

XT® WING PULLEY

ACCESSORIES

QD® Hub Selection



HUB SELECTION

When choosing a hub and bushing system, it is important to understand the different design features and the effects they have on conveyor pulley applications. Consider a design that minimizes end disk pre-stressing, grips the shaft firmly, is easily removed, and is not adversely affected by the bending moments on the pulley shaft.

QD® HUBS AND BUSHINGS

The QD® Hub and Bushing system was designed primarily for use in sprockets and sheaves with one hub and has been used widely in conveyor pulleys due to its availability. The QD® design has a shallow taper angle, 3/4" taper per foot, causes the end disk to deflect or pre-stress when bushings are installed. bushing, further reducing the chance of bushing breakage.

	QD® STYLE DRUM PULLEY						
	A	B	C	D	E	F	G
JA	0.687	1.000	0.437	0.500	1.500	0.562	1.125
SH	0.750	1.312	0.812	0.500	1.875	0.812	1.375
SDS	0.750	1.312	0.812	0.500	1.812	0.750	1.375
SK	0.812	1.937	1.437	0.500	2.000	1.000	1.563
SF	0.875	2.062	1.375	0.500	2.187	1.000	1.750
E	1.000	2.750	2.062	0.500	2.687	1.125	2.187
F	1.062	3.750	2.937	0.500	3.000	1.250	2.437
JS	1.250	3.375	1.812	0.500	3.125	1.625	2.500
MS	1.250	4.812	2.250	0.500	3.562	2.375	2.812
NS	1.312	6.000	2.750	0.500	4.062	2.375	3.250
PS	1.375	6.500	3.750	0.500	4.250	2.875	3.375
WS	1.562	7.250	4.125	0.500	4.750	3.375	3.813
SS	1.625	8.750	4.187	0.500	5.250	3.875	4.125
ZS	1.562	8.750	4.125	0.500	5.562	4.875	4.312

	QD® STYLE WING PULLEY						
	A	B	C	D	E	F	G
JA	0.562	1.000	0.562	0.375	1.375	0.563	1.000
SH	0.625	1.312	0.937	0.375	1.625	0.813	1.125
SDS	0.625	1.312	0.937	0.375	1.625	0.750	1.188
SK	0.687	1.937	1.562	0.375	2.063	1.000	1.625
SF	0.750	2.062	1.500	0.375	2.250	1.000	1.813
E	0.875	2.750	2.187	0.375	3.000	1.125	2.500
F	0.937	3.750	3.062	0.375	4.000	1.250	3.438
JS	1.000	3.375	1.937	0.375	3.375	1.625	2.750
MS	1.125	4.812	2.375	0.375	4.133	2.375	3.563
NS	1.187	6.000	2.875	0.313	5.625	2.375	4.813
PS	1.250	6.500	3.875	0.250	5.750	2.875	4.875
WS	1.437	7.250	4.250	0.313	6.250	3.375	5.313
SS	1.500	8.750	4.312	0.250	7.500	3.875	6.375
ZS	1.437	8.750	4.250	0.188	6.563	4.875	5.313

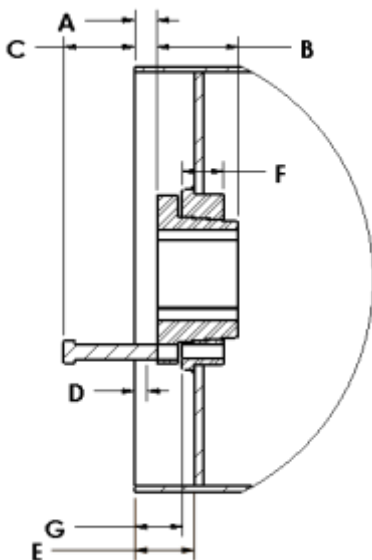

QD® DRUM PULLEY

*C: Space required to remove bushing using jackscrews with short hex key or open end wrench.

HUB SIZING

To select a hub size, choose the smallest hub that will allow the shaft size determined per ANSI/CEMA B105.1-1992. Torsional loading and shallow keyways may also affect hub sizing.

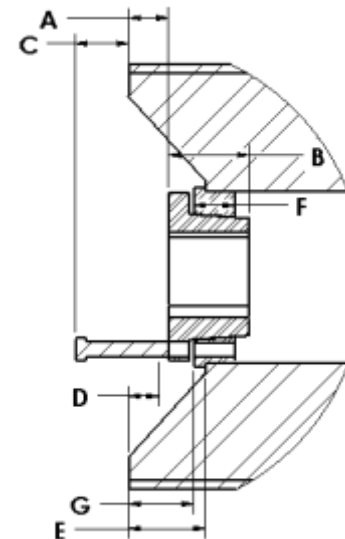

QD® WING PULLEY

Taper-Lock® Hub Selection

HUB SELECTION

When choosing a hub and bushing system, it is important to understand the different design features and the effects they have on conveyor pulley applications. Consider a design that minimizes end disk pre-stressing, grips the shaft firmly, is easily removed, and is not adversely affected by the bending moments on the pulley shaft.

TAPER-LOCK® HUBS AND BUSHINGS

The Taper-Lock® Hub and Bushing system was designed primarily for use in sprockets and sheaves with one hub and has been used widely in conveyor pulleys due to its availability. The Taper-Lock® design has a taper angle of 8 degrees or 1-11/16" taper per foot, which minimizes end disk deflection. However, of all hub and bushing systems, it has the lowest ability to grip the shaft. When a Taper-Lock® bushing is installed, it is flush with the outer surface of the hub providing a clean appearance.

TYPE-K TAPERED HUB	TAPERED BUSHING	TAPER-LOCK® STYLE DRUM PULLEY					
		A	B	C	D	E	F
K12	1210	0.750	1.000	3.120	0.750	1.062	0.875
K16	1610	0.750	1.000	3.120	0.750	1.062	0.875
K20	2012	0.750	1.250	0.625	0.750	1.062	1.000
K25	2517	0.750	1.750	0.875	0.750	1.125	1.500
K30	3020	0.750	2.000	1.312	0.750	1.125	1.625
K35	3535	0.750	3.500	1.937	0.750	1.250	1.625
K40	4040	0.750	4.000	2.625	0.750	1.250	2.125
K45	4545	0.750	4.500	3.312	0.750	1.375	2.625
K50	5050	0.750	5.000	4.062	0.750	1.375	2.875
K60	6050	2.000	5.000	2.375	0.906	2.625	2.875
K70	7060	2.000	6.000	2.375	0.906	2.750	3.375
K80	8065	2.000	6.500	2.375	0.906	2.750	3.625
K100	10085	2.000	8.500	3.375	0.687	3.000	4.125
K120	120100	2.000	10.000	3.375	0.687	3.000	5.375

TYPE-K TAPERED HUB	TAPERED BUSHING	TAPER-LOCK® STYLE WING PULLEY					
		A	B	C	D	E	F
K12	1210	1.437	1.000	0.000	1.438	1.875	0.875
K16	1610	1.437	1.000	0.000	1.438	1.875	0.875
K20	2012	1.687	1.250	0.000	1.688	2.250	1.000
K25	2517	1.625	1.750	0.000	1.625	2.243	1.500
K30	3020	1.750	2.000	0.375	1.750	2.500	1.625
K35	3535	2.750	3.500	0.000	2.750	5.125	1.625
K40	4040	2.750	4.000	0.625	2.750	5.125	2.125
K45	4545	2.625	4.500	1.500	2.625	5.125	2.625
K50	5050	3.375	5.000	1.500	3.375	6.125	2.875
K60	6050	3.375	5.000	1.000	3.375	6.125	2.875
K70	7060	3.250	6.000	1.125	3.250	6.625	3.375
K80	8065	3.250	6.500	1.125	3.250	6.875	3.625
K100	10085	4.000	8.500	1.375	4.000	9.375	4.125
K120	120100	4.000	10.000	1.375	4.000	9.625	5.375

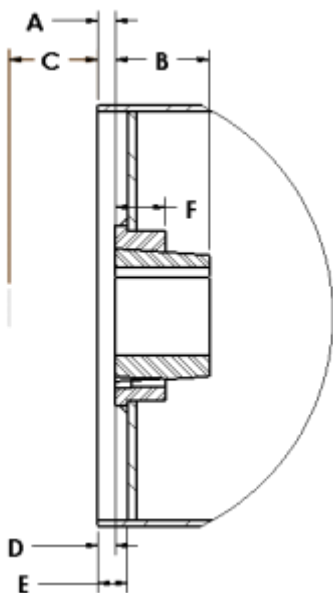

*C: Space required to remove bushing using jackscrews with short hex key or open end wrench.

HUB SIZING

To select a hub size, choose the smallest hub that will allow the shaft size determined per ANSI/CEMA B105.1-1992. Torsional loading and shallow keyways may also affect hub sizing.

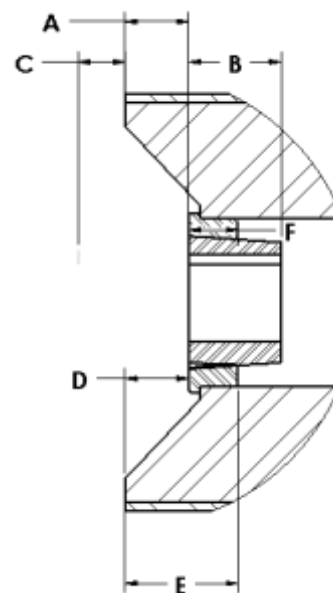

TAPER-LOCK® DRUM PULLEY

TAPER-LOCK® WING PULLEY