

# Pulley Quotation Worksheet

For selection assistance please consult "PCI PULLEY SELECTION GUIDE" or call PCI Customer Service at 989.358.6149.



COMPANY NAME / BRANCH NO. \_\_\_\_\_ COMPANY PHONE NO. \_\_\_\_\_

YOUR NAME \_\_\_\_\_ EMAIL ADDRESS \_\_\_\_\_

QUANTITY \_\_\_\_\_ ACCESSORIES REQUIRED: TAKE-UP FRAME PART# \_\_\_\_\_ BEARING PART# \_\_\_\_\_ BORE SIZE \_\_\_\_\_

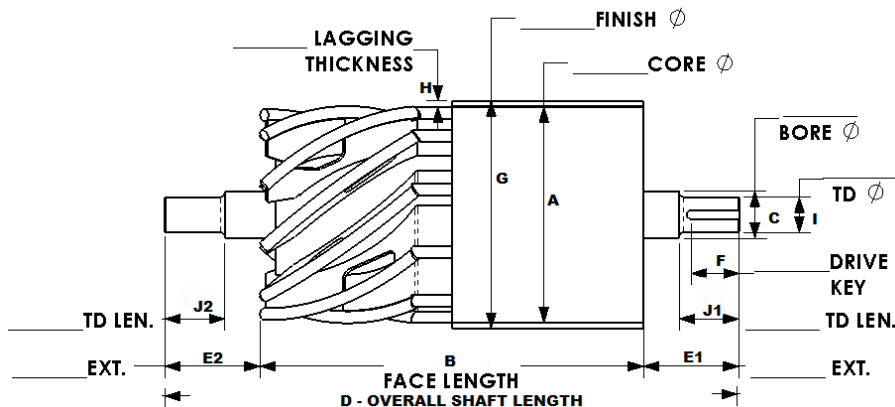

<p><b>PULLEY POSITION:</b> <input type="checkbox"/> Drive <input type="checkbox"/> Tail <input type="checkbox"/> Snub <input type="checkbox"/> Take-Up <input type="checkbox"/> Bend</p> <p><b>PULLEY PROFILE:</b> <input type="checkbox"/> Flat Face <input type="checkbox"/> Crowned Face <input type="checkbox"/> V-Groove: _____ Section Special V: _____ X _____ X _____</p> <p><b>PULLEY CONFIGURATION:</b> (choose one)</p> <p>Drum-Package Handling: <input type="checkbox"/> FC Series <input type="checkbox"/> MC Series</p> <p>Drum- Bulk Handling: <input type="checkbox"/> Standard Duty <input type="checkbox"/> Heavy Duty <input type="checkbox"/> Mine Duty</p> <p>WING (traditional): <input type="checkbox"/> Standard Duty <input type="checkbox"/> Heavy Duty <input type="checkbox"/> Mine Duty <input type="checkbox"/> Other _____</p> <p>ERADICATOR®: <input type="checkbox"/> Standard Duty <input type="checkbox"/> Heavy Duty <input type="checkbox"/> Mine Duty</p> <p>ERADICATOR®-MAX: <input type="checkbox"/> Standard Duty <input type="checkbox"/> Heavy Duty <input type="checkbox"/> Mine Duty</p> <p>ERADICATOR®D2®: <input type="checkbox"/> Standard Duty <input type="checkbox"/> Heavy Duty <input type="checkbox"/> Mine Duty Discharge: <input type="checkbox"/> Right <input type="checkbox"/> Left</p> <p>ICE-ERADICATOR®: <input type="checkbox"/> Standard Duty <input type="checkbox"/> Heavy Duty <input type="checkbox"/> Mine Duty</p> <p>STAINLESS: <input type="checkbox"/> Sanitary Class <input type="checkbox"/> Super Clean <input type="checkbox"/> Easy Clean <input type="checkbox"/> Extra Value</p> <p><b>HUB TYPE:</b> (choose one) Type C Internal bearings not available on Ice-Eradicator®</p> <p>TYPE A: <input type="checkbox"/> Plain Bore <input type="checkbox"/> With Welded Shaft</p> <p>TYPE B: <input type="checkbox"/> Keyed Hub with Set Screws</p> <p>TYPE C: <input type="checkbox"/> "ER" Style Internal Bearings <input type="checkbox"/> Dead Shaft</p> <p>CH&amp;B: <input type="checkbox"/> XT® <input type="checkbox"/> QD® <input type="checkbox"/> TAPERLOCK® <input type="checkbox"/> XT® INTEGRAL ENDS Preferred Hub Size _____</p> <p>KLD: <input type="checkbox"/> Keyless Locking Devices Brand Preference _____</p>	<p><b>A.</b> Core Diameter _____ Pulley Core Thickness _____</p> <p><b>B.</b> Face Length _____</p> <p><b>C.</b> Main Shaft/Bore Dia. _____</p> <p><b>D.</b> OA Shaft Length _____</p> <p><b>E1.</b> Extension Length _____</p> <p><b>E2.</b> Extension Length _____</p> <p><b>F.</b> Keyway Length _____</p> <p><b>G.</b> Finish Diameter _____</p> <p><b>H.</b> Lagging Thickness _____</p> <p><b>I.</b> Turndown Dia. _____ <input type="checkbox"/> One End <input type="checkbox"/> Both Ends</p> <p><b>J1.</b> Turndown Length _____</p> <p><b>J2.</b> Turndown Length _____</p> <p>Bearing Centers _____</p>
--------------------------------------------------------------------------------------------------------------------------------------------------------------------------------------------------------------------------------------------------------------------------------------------------------------------------------------------------------------------------------------------------------------------------------------------------------------------------------------------------------------------------------------------------------------------------------------------------------------------------------------------------------------------------------------------------------------------------------------------------------------------------------------------------------------------------------------------------------------------------------------------------------------------------------------------------------------------------------------------------------------------------------------------------------------------------------------------------------------------------------------------------------------------------------------------------------------------------------------------------------------------------------------------------------------------------------------------------------------------------------------------------------------------------------------------------------------------------------------------------------------------------------------------------------------------------------------------------------------------------------------------------------------------------------------------------------------------------------------------------------------------------------------------------------------------------------------------------------------------------------------------------------------------------------------------------------------------------------------------------------------------------------------------------------------------------------------------------------------------------------------------------------------------------------------------------------------------------------------------------------------------------------------------------------------------------	-----------------------------------------------------------------------------------------------------------------------------------------------------------------------------------------------------------------------------------------------------------------------------------------------------------------------------------------------------------------------------------------------------------------------------------------------------------------------------------------------------------------------------------------------------------------------------------------------------------------------------

**LAGGING:** Durometer \_\_\_\_\_ Thickness \_\_\_\_\_ Color Preference \_\_\_\_\_

TYPE:  S.B.R.  Carboxylated Nitrile  E.P.D.M.  Neoprene  Nitrile  Urethane  S.W.R.T.  Weld-On  Ceramic  Food Grade

GROOVING:  HERRINGBONE  CHEVRON  DIAMOND GROOVE DIRECTION:  Clockwise  Counterclockwise

**KNURLING** – Teeth Per Inch (TPI) ON CONTACT SURFACE  Fine (25 TPI)  Medium (16 TPI)  Coarse (10 TPI)

**ICE-ERADICATOR® PARAMETERS:**  USA  Canada  Other (Specify) \_\_\_\_\_

**OPERATING TIME:** Hours/day \_\_\_\_\_ Days/week \_\_\_\_\_ Weeks/year \_\_\_\_\_ **BELT SPEED (ft/min):** \_\_\_\_\_ **Lowest Temp:** \_\_\_\_\_ °F \_\_\_\_\_ °C



(989)358-6149

www.pcimfg.com