

# CONVEYOR PULLEYS

## Wing Pulleys – The Eradicator®



The Eradicator® wing pulley combines the best features of a traditional wing pulley with several unique performance enhancing characteristics to create the optimum self-cleaning solution.

### DESIGN BENEFITS...

- Accelerated Cleanout
- Increased Component Life
- Quieter Operation
- Enhanced Belt Tracking

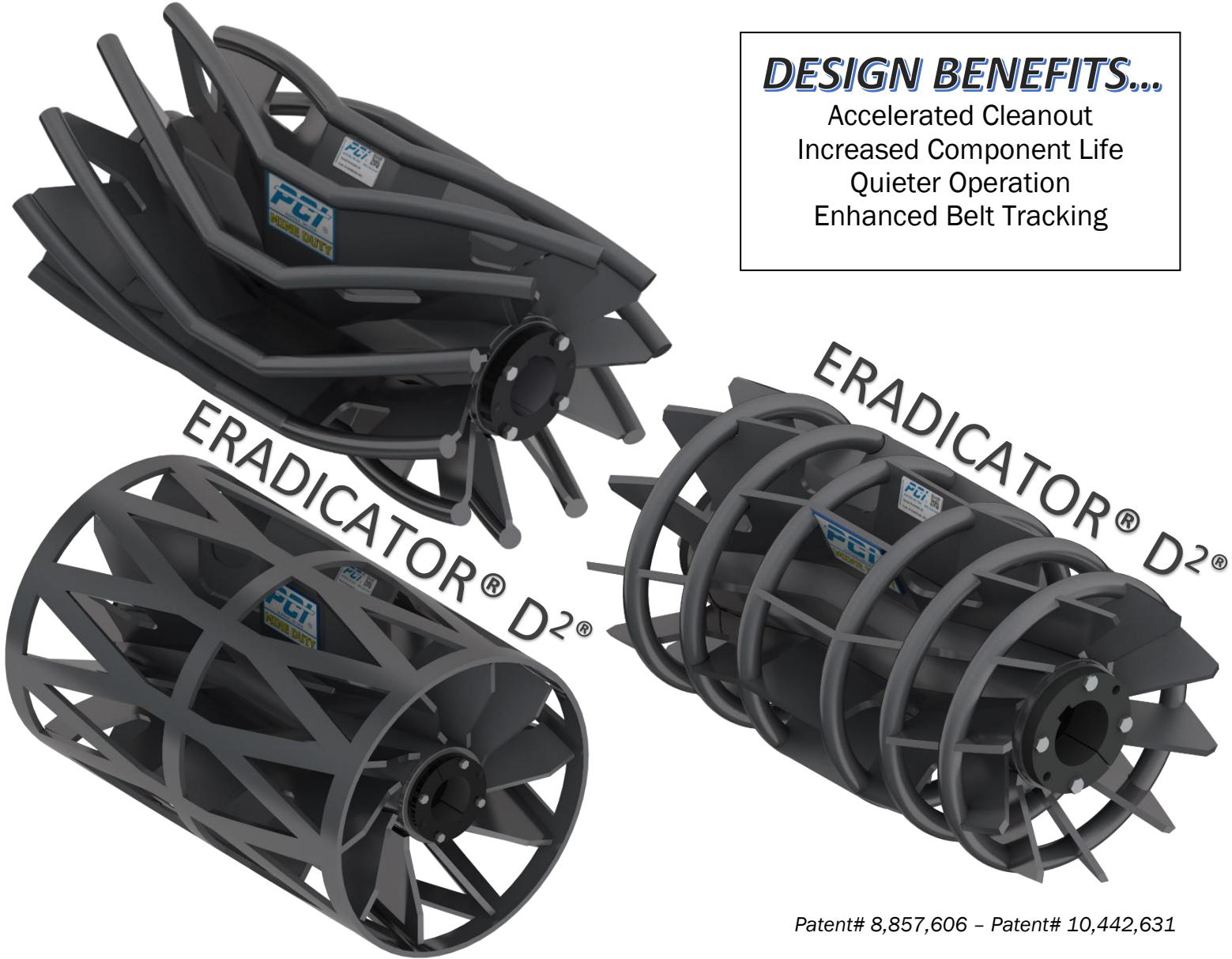

Patent# 8,857,606 – Patent# 10,442,631

### DIAMETERS AVAILABLE

6" through 48"

THICKNESSES	WING	WING TIP
Standard Duty	7 gauge(.180")	3/4" Round
Heavy Duty	1/4"	1" Round
Mine Duty	3/8"	1-1/4" Round
Tipless	3/8"	-

### HUB STYLES AVAILABLE

Welded Compression Hubs/Bushings (Type 4)  
Dead Shaft Assembly

“AR” ABRASION RESISTANT MATERIALS AVAILABLE  
UPON REQUEST



(989)358-6149

www.pcimfg.com

# CONVEYOR PULLEYS

## Focus Flyer – The Eradicator®



The Eradicator® wing pulley combines the best features of a traditional wing pulley with several unique performance enhancing characteristics to create the optimum self-cleaning solution.



PRODUCT DASHBOARD			
CLEANOUT RATE <b>40x</b> FASTER	MATERIAL SIZE ALL	SINGLE DIRECTION 	NOISE 

Patent# 8,857,606

**FAILURE FREE**  
**SINCE 2016**

WATCH THE VIDEO



[www.pcimfg.com/portfolio\\_page/the-eradicator/](http://www.pcimfg.com/portfolio_page/the-eradicator/)



ALSO AVAILABLE WITH  
ERADI-LAG™ & "AR" WING TIPS

## DESIGN BENEFITS...

### ACCELERATED CLEANOUT

The Eradicator dominates material displacement by forcing particulate away from its center toward its open ends. PCI's exclusive design retains a traditional wing pulley's belt slapping capability to prevent material buildup while the cleanout ports maximize the material removal rate and minimize recirculation of material. These patented features power the Eradicator with a cleanout rate up to **40 times faster** than a traditional wing pulley, creating the ultimate in self-cleaning solutions.

### INCREASED LIFE

The hybrid design of The Eradicator maximizes both the life of the pulley and the conveyor belt. PCI's self-reinforced design discourages wing fold over and prevents incidental damage to the pulley. The Eradicator also maximizes belt life by reducing deformation commonly associated with high center point designs.

### ENHANCED BELT TRACKING

The unique profile of the Eradicator encourages conveyor belt tracking by continually guiding the belt with its curved and angled wing members towards a reliable flat center point. This tracking benefit reduces the reliance on routine maintenance and the need for other belt training devices.

### QUIETER OPERATION

The Eradicator decreases noise by continuously contacting the belt while its straight center maximizes cleanout. Only the Eradicator achieves the optimum balance of noise reduction and cleanout efficiency.



(989)358-6149

[www.pcimfg.com](http://www.pcimfg.com)

# CONVEYOR PULLEYS

## Focus Flyer – The Eradicator®



### *How is PCI's Eradicator different from a traditional Wing Pulley?*

The Eradicator wing pulley retains the belt cleaning benefits of a traditional wing while providing continuous belt contact and improved cleanout efficiency. These additional benefits provide longer component life and decreased noise. Traditional wing pulleys feature straight wings that contact the belt intermittently, entrapping and recirculating material rather than displacing it, often leading to belt damage and pulley failure.

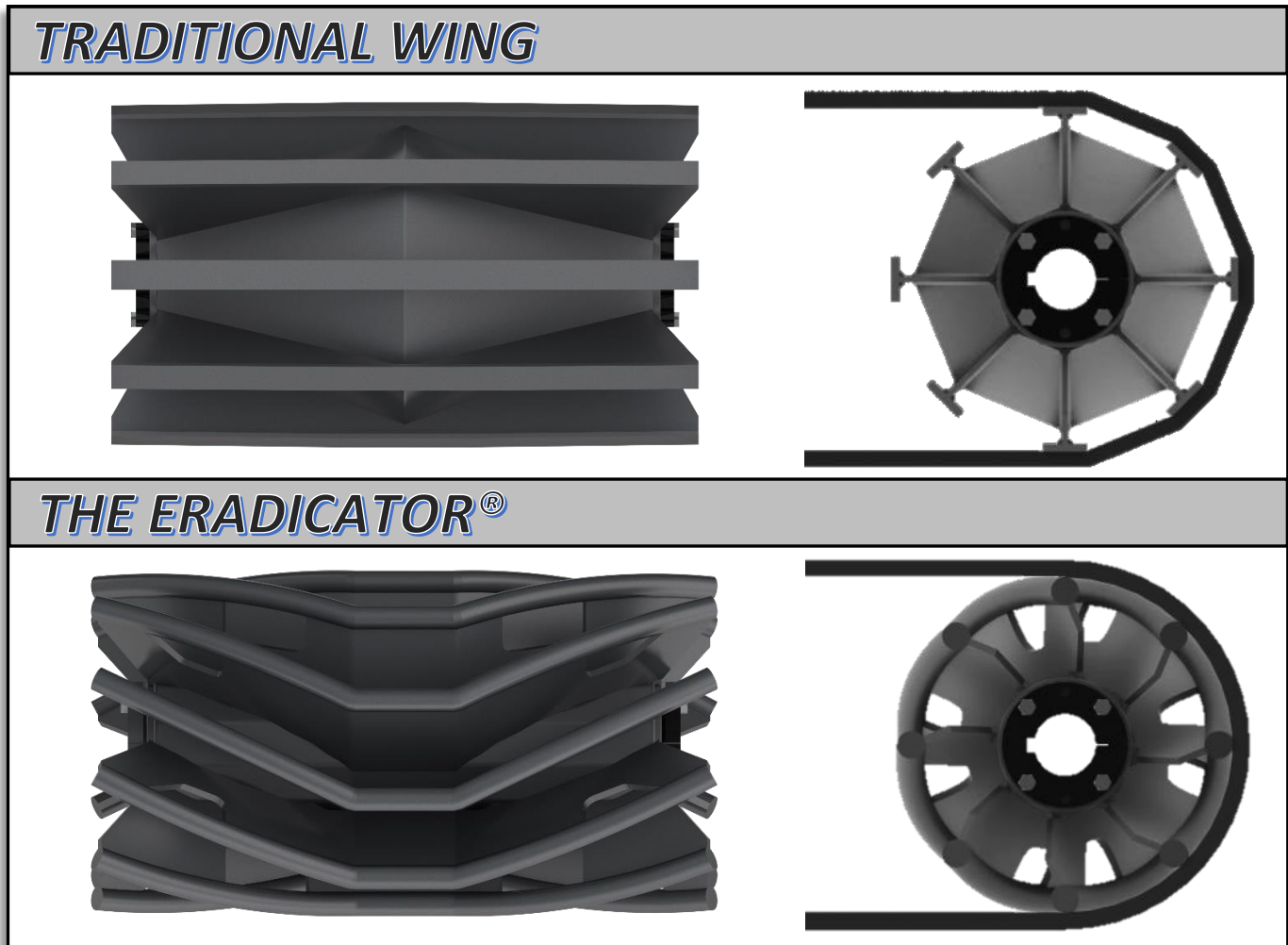

### *What applications benefit from using the Eradicator Wing Pulley?*

Applications where loose materials are causing damage to either the belt or conveyor pulleys would benefit from the use of The Eradicator. In addition to solving cleanout problems, PCI's Eradicator decreases operating noise compared to traditional wing designs, making it ideal for applications where noise reduction is also desired.

### *How does The Eradicator Wing Pulley compare to other enhanced wing pulley designs?*

Although other wing products may offer similar benefits, no other product offers the combination of benefits provided by the hybrid design of PCI's Eradicator wing pulley. Spiral wing designs achieve continuous belt contact but underperform in material removal because of their straight wing members. Other enhanced wing products feature a center high point, eliminating the beater bar benefits of a traditional wing and may cause additional belt deformation with reduced belt tracking capability. The hybrid design of The Eradicator retains the belt cleaning benefits of a traditional wing while enhancing cleanout efficiency, offering unparalleled overall performance.

Patent# 8,857,606