

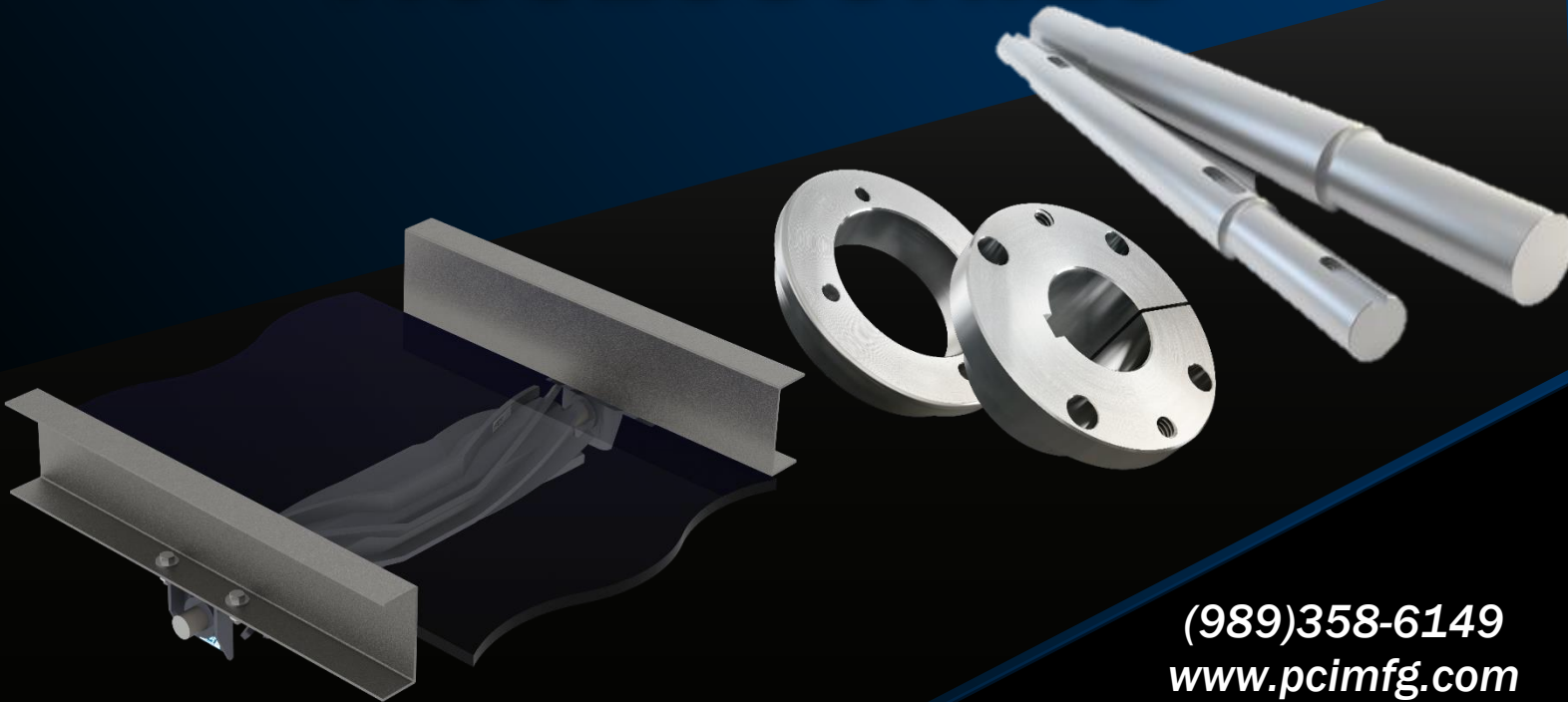

Solutions Through Innovation

CONVEYING COMPONENTS & ACCESSORIES



(989)358-6149
www.pcimfg.com

Eradiator[®] Max Return Rolls

Patent # 8,857,606

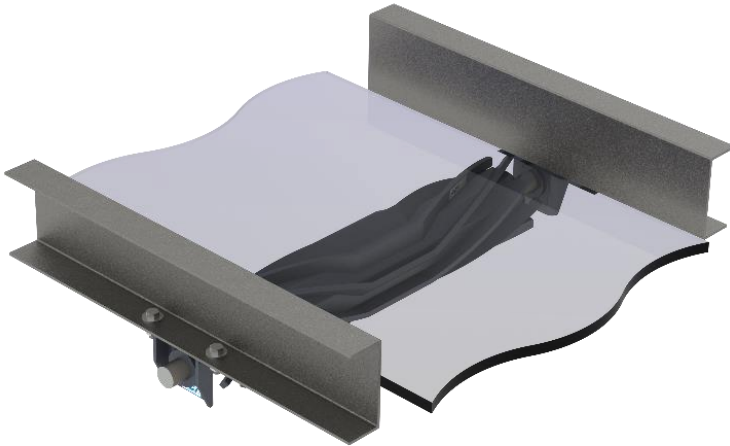

The PCI[®] patented Eradiator[®] Max Return Rolls address the performance shortfalls commonly associated with beater bar, squirrel cage and rubber disk style return rolls by optimizing cleanout, maximizing unit strength, and multiplying the serviceable hours of the unit.

Deflection Wheels

PCI manufactures deflection wheels for use with flexwall belt, corrugated sidewall belting or “Boxwall” conveyors. The wheels guide the belting through curves on the conveyor and are used on both conveying and returning sides.

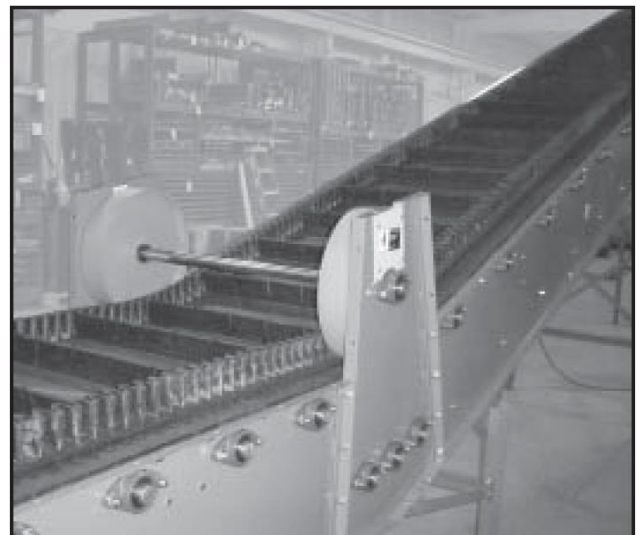

CONVEYING COMPONENTS & ACCESSORIES



Shafting



Common details and custom modifications include

- Turn Downs (single, double, multiple)
- Keyways (single, double, multiple, full)
- Retaining Ring Grooves
- Threading (Internal & External)
- Thru Holes
- Milled Flats
- Keeper Bar Slots

Materials Available

- C1045
- C1018
- C1144
- Turned, Ground & Polished
- Fully Keyed
- 303/304/316 Stainless

Lagging & Coating



- Hot Vulcanized or Cold Bond Materials
- Ceramic and Urethane Compounds
- Weld-on Styles featuring PCI's patented Eradi-Lag™



PCI's Eradi-Lag™
Patent #11,142,404



(989)358-6149

www.pcimfg.com

CONVEYING COMPONENTS & ACCESSORIES



Take-Up Frames

Center Pull

A versatile, top mounted, in-line frame used with a variety of wide-slot bearings.

Narrow & Wide Slot

Economical side mount in-line frame designed for narrow & wide slot take-up bearings.

Telescoping

Economical side mount frame, which extends beyond the conveyor frame for use with pillow block bearings.



Top Angle

Heavy duty top mounted design provides durable adjustment screw protection for round bottom take-up bearings.

Protected Screw

Light & Heavy Duty top mount designs for use with standard pillow block bearings.

Exclusive Tension Indicating Scale Options

For real time readout on Telescoping frames.

Take-Up Frame Bearings and Covers are in stock and readily available.

Stainless Steel Hubs & Bushings

**300 Series Stainless Steel
XT®, HE, QD® and Taper-Lock® Styles**

Precision Machined
Stock Availability
Inch and Metric Bore Sizes

Made in the USA





RETURN ROLLS

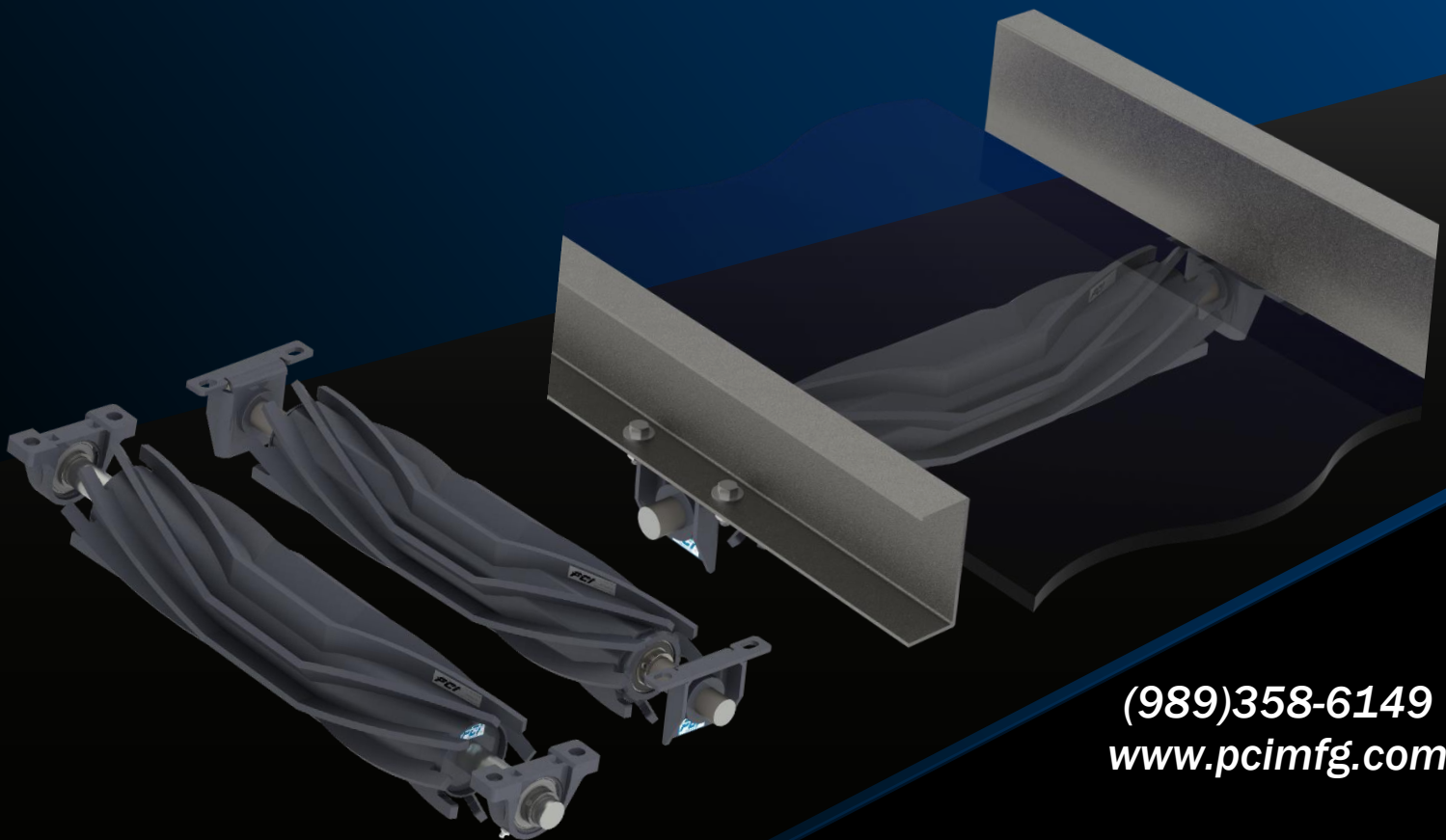

(989)358-6149
www.pcimfg.com

CONVEYING COMPONENTS

Return Rolls

Eradicator Max[®] Return Rolls



Return Rolls are typically installed on the underside of a conveyor to provide support to the returning conveyor belt. The PCI[®] patented Eradicator[®] Max Return Rolls address the performance shortfalls commonly associated with beater bar, squirrel cage and rubber disk style return rolls by optimizing cleanout, maximizing unit strength, and multiplying the serviceable hours of the unit.

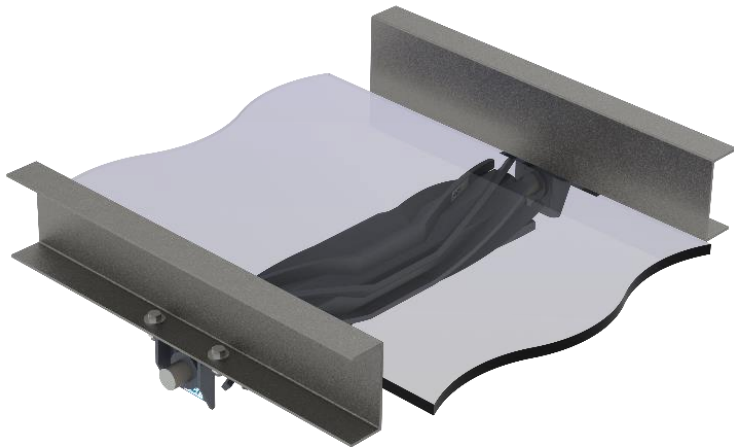

DESIGN BENEFITS

Accelerated Cleanout

Increased Shaft Capacity

Available in Both Live Shaft and Dead Shaft Configurations

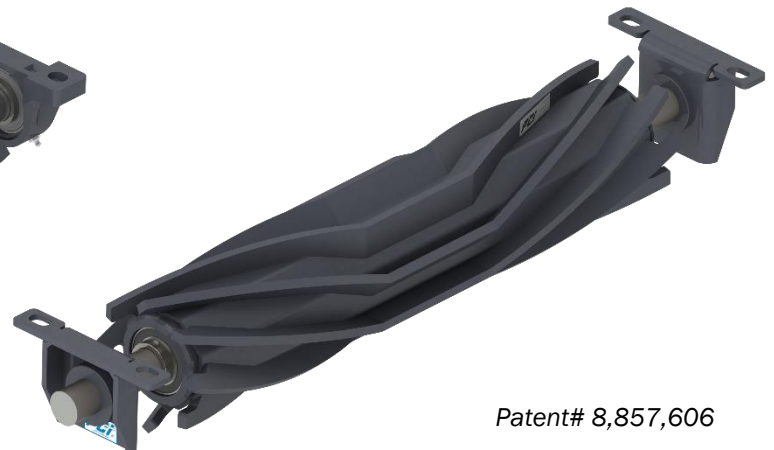

Patent# 8,857,606

Optimizing Cleanout: PCI Eradicator Max return rolls not only support the belt, but also create the ultimate in self-cleaning solutions with patented angled wings that force particulate away from its center toward its open ends.

Maximizing Unit Life: PCI Eradicator Max angled wings provide debris protection by removing abrasive materials from the roll core while the thicker wings create a deeper wear surface than typical tube roll or beater bar styles.

Increasing System Uptime: PCI Eradicator Max return roll's innovative designs allow increased shaft sizes to accommodate bearings with a longer L10 life. In addition, by ejecting unwanted material that damage components, the Eradicator Max return roll helps minimize maintenance and downtime.

CONVEYING COMPONENTS

Deflection Wheels

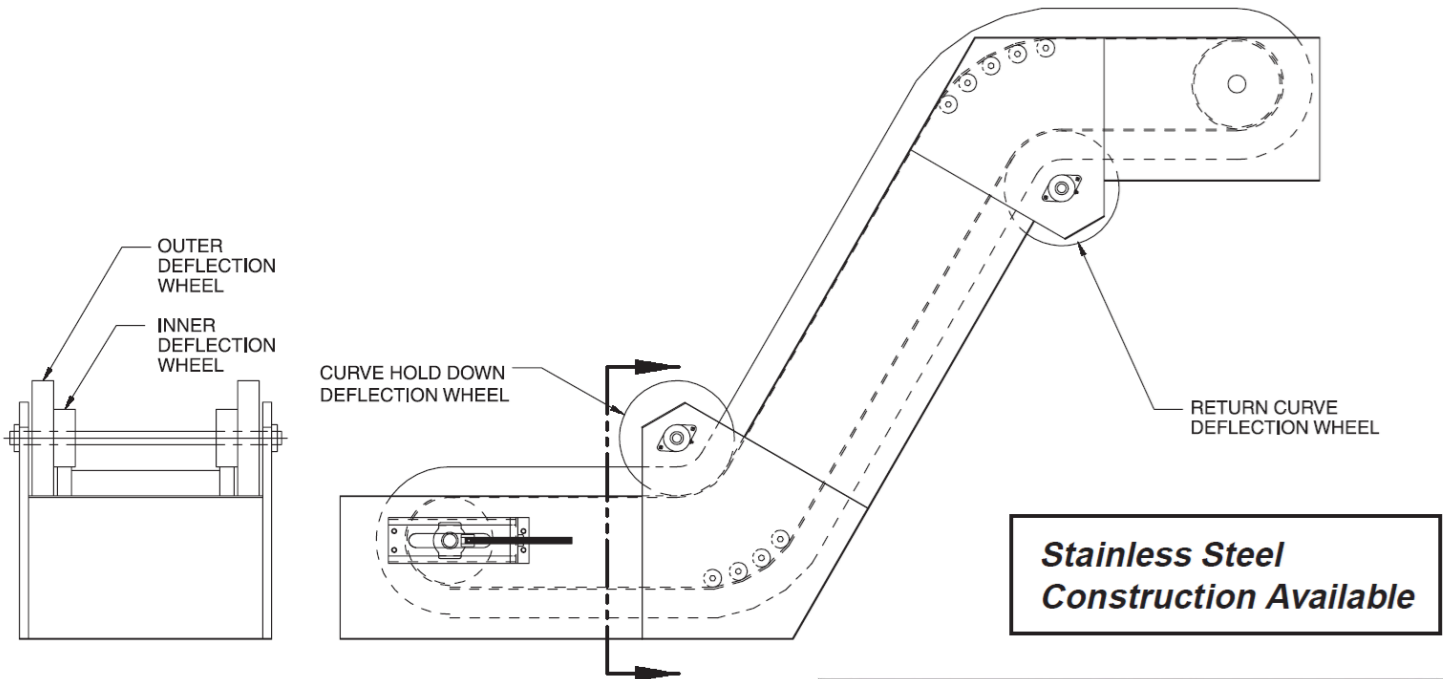

PCI[®] manufactures deflection wheels for use with corrugated side wall belting on “Boxwall” conveyors. The wheels guide the belting through curves on the conveyor and are used on both conveying and returning sides. Made-to-order deflection wheels are available in a wide variety of sizes and hub combinations. Inner deflection wheels are typically supplied with bearings or oil-impregnated bronze bushings.

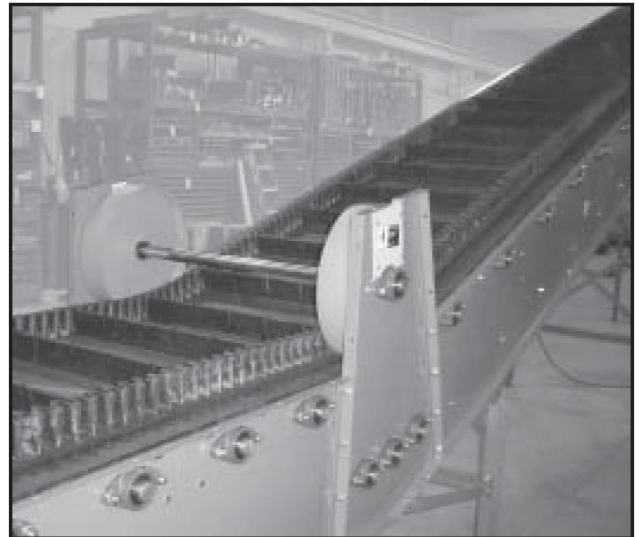

Assemblies including mounting shafts can be supplied upon request

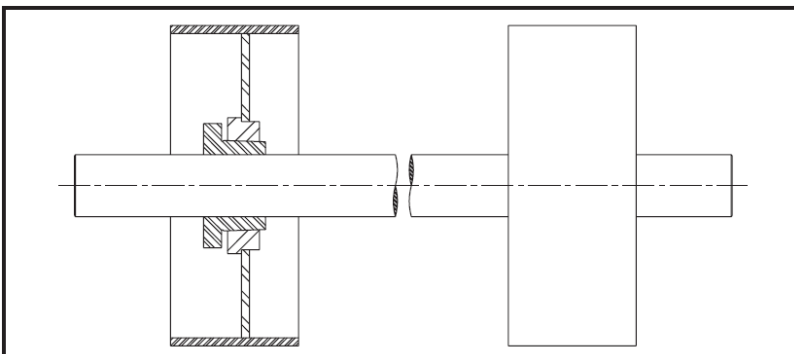

CONVEYING COMPONENTS

Shafting



High quality shafting plays a critical role in the performance of a conveyor pulley assembly. PCI® shafting capabilities cover a broad spectrum of applications for our customers, from unit handling to shafts used in large scale mine and quarry operations, making PCI your *one-stop-shop* for conveyor accessories.



Common details and custom modifications include

- Turn Downs (single, double, multiple)
- Keyways
- Retaining Ring Grooves
- Threading (Internal & External)
- Thru Holes
- Milled Flats
- Keeper Bar Slots

Materials Available

- C1045
- C1018
- C1144
- Turned, Ground & Polished
- Fully Keyed
- 303/304/316 Stainless

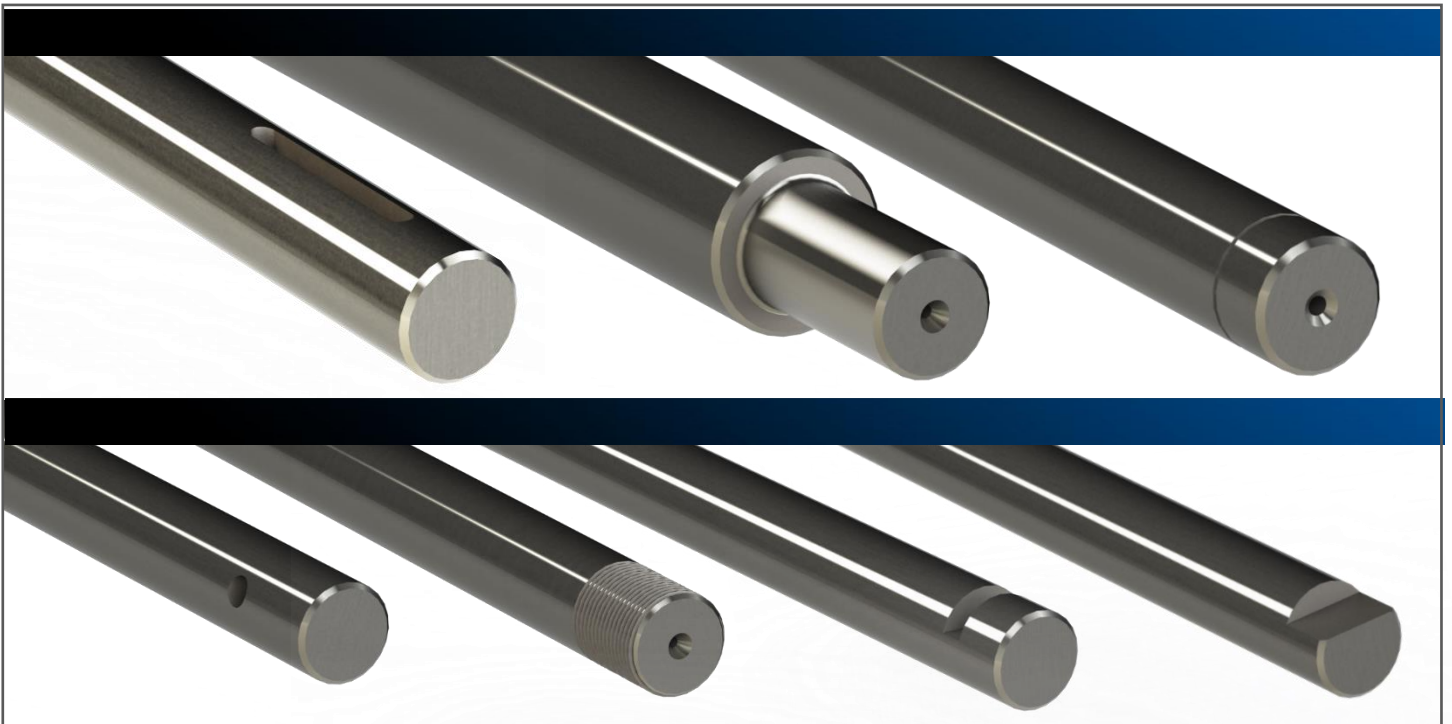



LAGGING & COATINGS

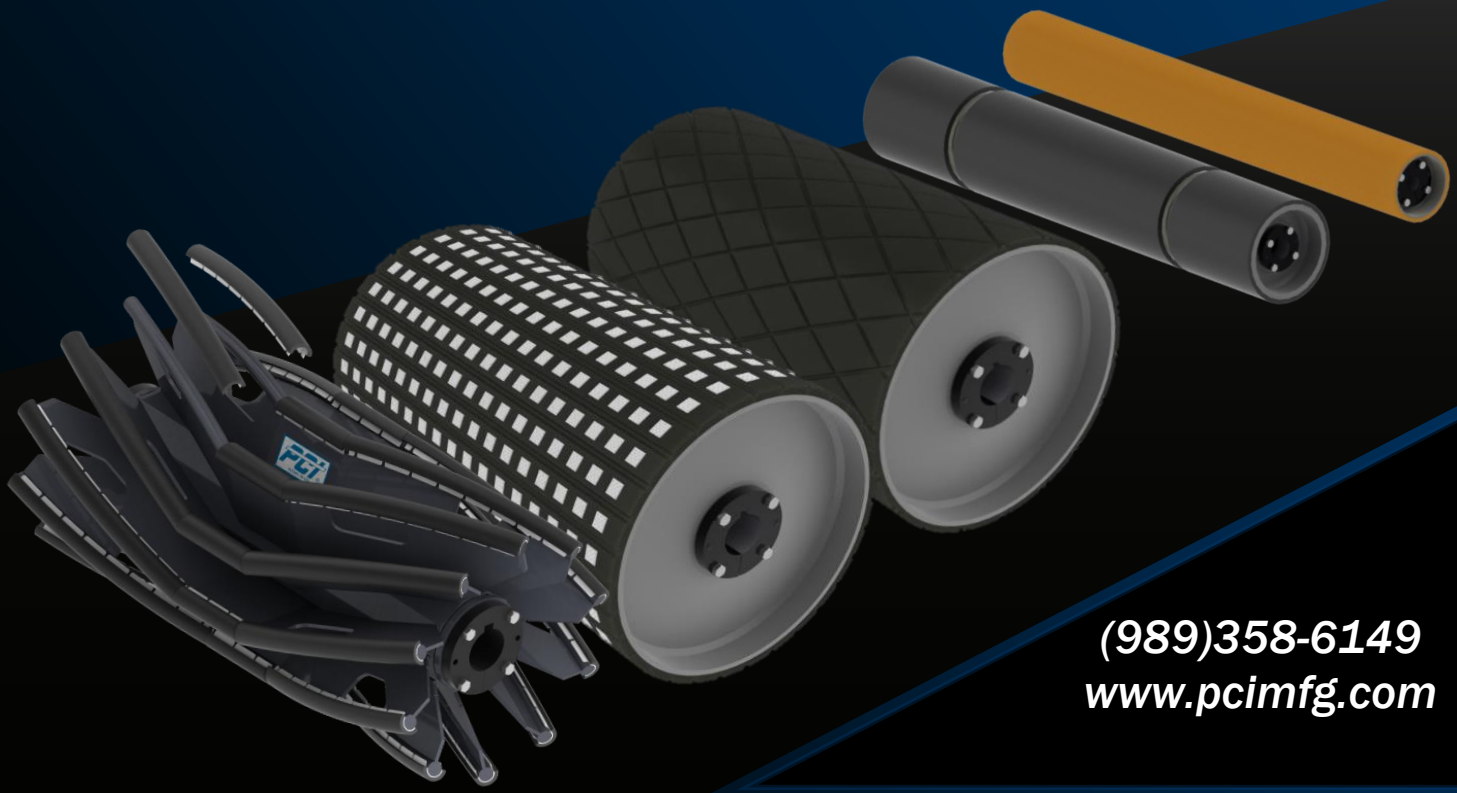

(989)358-6149
www.pcimfg.com

ACCESSORIES

Lagging & Coating Products



The term lagging describes a variety of elastomers used to coat the contact surface of a conveyor pulley. Its primary purpose is to enhance traction by increasing the coefficient of friction between the surfaces. The enhanced friction may also improve belt life by allowing lower belt tensions and reducing abrasive conditions between the pulley and belt. PCI® offers two types of lagging products; those that are hot vulcanized and those that are cold bonded using adhesives or mechanical agents. Most hot vulcanized lagging products can be formulated using Food Grade Materials and modified to include several groove patterns (Chevron, Herringbone, Diamond, etc.).

Hot Vulcanized

An elastomer in its raw state is extruded and wrapped around the circumference of the conveyor pulley. The pulley is then processed in an autoclave to cure the rubber, ground to size and grooved (if specified).

Vulcanized lagging is specified by selecting a rubber compound and durometer (hardness). A variety of standard compounds are available:

Styrene Butadiene Rubber (SBR)	Nitrile (NBR)	Natural (Gum) Rubber
Carboxylated Nitrile (XNBR)	Neoprene	Urethane
	Silicone	EPDM

Weld-On

60A Durometer rubber is vulcanized to steel plates that are formed to the shape of the pulley rim. These rubberized plates are held in place by retainers which are welded or bolted to the rim. This style of lagging has either diamond grooves or a smooth surface and is field replaceable without removing the pulley from the conveyor.

Ceramic

Individual dimpled ceramic drive tiles are molded into a base of premium grade rubber. The combination of the ceramic tiles and the rubber compound provides improved traction and abrasion resistance especially in wet or heavily soiled environments.

Spiral Wrap Rough Top

Spiral Wrap Rough Top (SWRT) is 2-ply 60A Durometer SBR belting that is wrapped around the pulley and secured with adhesive & rivets. SWRT has a nubby, rough profile for added traction. Resilient lagging is also available upon request. These options are not recommended on pulleys over 12" dia.

Wing Tip Lagging

Wing tips are the primary wear component of a wing style pulley. To increase the service life of a wing pulley, PCI offers: 70A Durometer Weld-On Diamond Urethane, 90A Durometer Slide-On Smooth Urethane and Eradi-Lag™ for angled wing products. All options are field replaceable.

CONVEYOR PULLEYS

Focus Flyer – Eradi-Lag™



PCI's patented Eradi-Lag™ is an innovative approach to wing pulley lagging for the Eradicator® or on any round bar angled wing pulley product. Eradi-Lag is constructed using a proprietary blend of 60A SBR for maximum wear life and a weldable steel backing plate for ease of installation. Maximize the longevity of your Eradicator with Eradi-Lag.



Patent #11,142,404

AVAILABLE FOR ROUND BAR DIAMETERS

$\frac{3}{4}$ " - 1" - 1 $\frac{1}{4}$ " - 1 $\frac{1}{2}$ "

Steel backed to be formed and welded directly to the contact bar for maximum strength

Can be formed and installed on the Eradicator® or any angled wing pulley product

Proprietary blend of 60A Durometer SBR for maximum wear life



TAKE-UP FRAMES



(989)358-6149
www.pcimfg.com

CONVEYING COMPONENTS

Take-Up Frames Narrow Slot

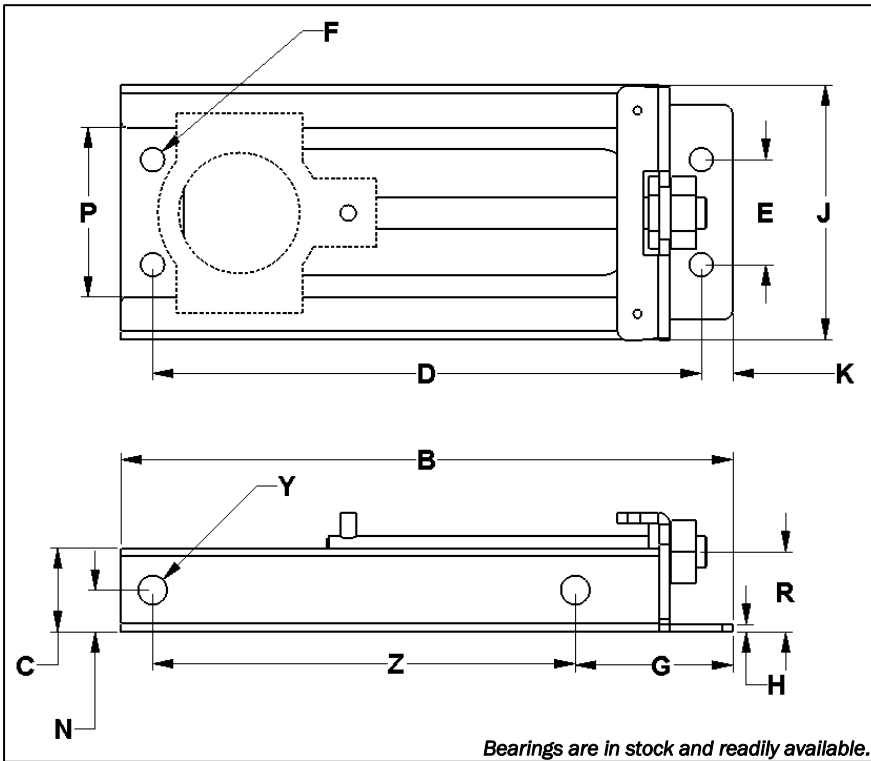

Bearings are in stock and readily available.



Available in 304 Stainless Steel construction, add "-SS" to the part number. For Example: 1400-SS.

PCI Part#	Size	Travel	B	C	D	E	F		G	H	J	K	N	P	R	S Rod Dia.	Y	Z	Approx. Weight (lbs.)	Optional Cover
							No.	Bolt Dia.												
1400	100	6	13 5/8	1 1/2	12 1/8	1 5/8	4	9/16	3 9/16	1/8	3 13/16	3/4	3/4	2 11/16	1 3/8	3/4	9/16	9 5/16	5.5	1400C
1401	108	6	13 5/8	1 1/2	12 1/8	2 1/4	4	9/16	3 9/16	1/8	4 11/16	3/4	3/4	3 9/16	1 13/32	3/4	9/16	9 5/16	5.8	1401C
1402		12	19 5/8		18 1/8													15 5/16	8	1402C
1403	200	6	14 9/16	2	13 1/16	2 1/2	4	9/16	3 3/4	3/16	6 1/16	3/4	1	4 1/16	1 29/32	3/4	11/16	10 1/16	9.2	1403C
1404		9	18 5/8		17 1/8													14 1/8	11.3	1404C
1405		12	20 9/16		19 1/16													16 1/16	12.5	1405C
1406		18	27 5/8		26 3/8													23 1/8	16.3	1406C
1407	225	9	19 1/8	2	17 3/8	2 3/4	4	11/16	4 1/4	3/16	6 1/2	1	1	4 1/2	1 29/32	1	11/16	14 1/8	13.1	1407C
1408		18	28 1/8		26 3/8													23 1/8	18.6	1408C
1409	250	9	19 1/8	2	17 3/8	3	4	11/16	4 1/4	3/16	7	1	1	5	1 29/32	1	11/16	14 1/8	15.5	1409C
1410		18	28 1/8		26 3/8													23 1/8	19.1	1410C

Optional Take-Up Frame Covers

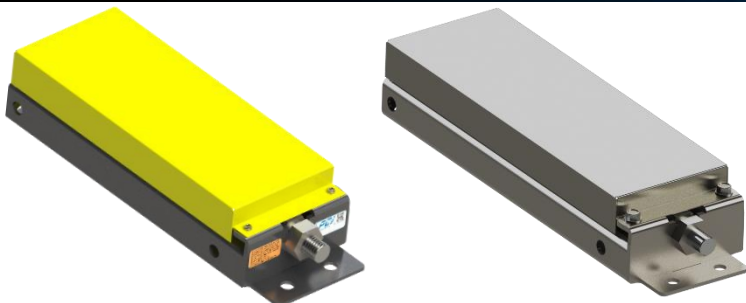

Covers

PCI Take-Up Frame covers are designed to protect internal components and are powder coated safety yellow to identify hidden moving components. To specify, add a "C" onto the part number of the corresponding frame.

For Example: 1400/1400C.

Covers are available in 304 Stainless Steel Construction. To specify Stainless Steel, add a "-SS" to the part number. For example: 1400C-SS.

CONVEYING COMPONENTS

Take-Up Frames

Wide Slot – Standard Duty

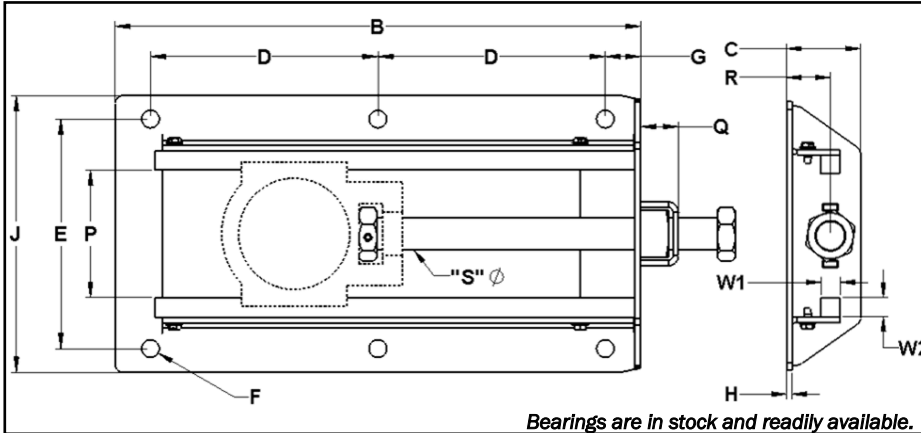

Bearings are in stock and readily available.



Available in 304 Stainless Steel construction, add “-SS” to the part number. For Example:1411-SS.

PCI Part#	Size	Travel	B	C	D	E	F		G	H	J	P	Q	R	S Rod Dia.	W ₁	W ₂	Approx. Weight (lbs)	Optional Cover
							No.	Bolt Dia.											
1411	100	1 1/2	7 1/2	1 3/4	5 3/8	5 9/16	4	1/2	1	3/16	6 9/16	3 1/16	13/16	1 1/16	5/8	1/2	1/2	3.5	1411C
1412		3	9		6 7/8													4.2	1412C
1413		6	12		4 15/16													5.5	1413C
1414		9	15		6 7/16													6.9	1414C
1415		12	18		7 15/16													8.3	1415C
1416	108	3	9 1/8	2	6 7/16	6 1/16	4	1/2	1	3/16	7 1/16	3 9/16	1	1 1/4	3/4	1/2	1/2	4.7	1416C
1417		6	12 1/8		9 7/16													6.3	1417C
1418		9	15 1/8		6 7/32													7.8	1418C
1419		12	18 1/8		7 23/32													9.4	1419C
1420		18	24 1/8		10 23/32													12.5	1420C
1421	200	3	10 3/4	2 7/16	8 1/2	7 5/16	4	9/16	1 1/8	3/16	8 13/16	4 1/16	1 3/16	1 7/16	1	5/8	5/8	7.8	1421C
1422		6	13 3/4		11 1/2													10.1	1422C
1423		9	16 3/4		7 1/4													12.3	1423C
1424		12	19 3/4		8 3/4													15	1424C
1425		18	25 3/4		11 3/4													19	1425C
1426	208	6	14 3/4	2 5/8	12 1/2	8 5/8	4	5/8	1 1/8	3/16	10 7/16	5 3/16	1 1/2	1 1/2	1 1/4	1	1/2	12	1426C
1427		9	17 3/4		15 1/2													15	1427C
1428		12	20 3/4		9 1/4													17	1428C
1429		15	23 3/4		10 3/4													20	1429C
1430		18	26 3/4		12 1/4													23	1430C
1431	24	32 3/4	15 1/4	28	1431C														
1432	300	9	20 7/8	3 3/8	17 1/2	10 1/4	4	11/16	2 1/2	1/4	12	6	1 3/4	2	1 1/2	1	1/2	26	1432C
1433		12	23 7/8		10 1/4													30	1433C
1434		18	29 7/8		13 1/4													37	1434C
1435		24	35 7/8		16 1/4													45	1435C
1436		30	41 7/8		19 1/4													53	1436C
1437	308	12	23 7/8	3 3/8	10 1/4	10 13/16	6	11/16	2 1/2	1/4	12 9/16	6 9/16	1 3/4	2	1 1/2	1	1/2	30	1437C
1438		18	29 7/8		13 1/4													38	1438C
1439		24	35 7/8		16 1/4													45	1439C
1440		30	41 7/8		19 1/4													53	1440C

Optional Take-Up Frame Covers

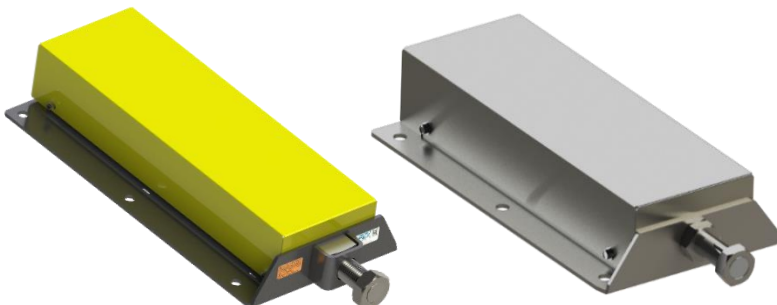

Covers

PCI Take-Up Frame covers are designed to protect internal components and are powder coated safety yellow to identify hidden moving components. To specify, add a “C” onto the part number of the corresponding frame.

For Example: 1411/1411C.

Covers are available in 304 Stainless Steel Construction. To specify Stainless Steel, add a “-SS” to the part number. For example: 1411C-SS.

CONVEYING COMPONENTS

Take-Up Frames

Wide Slot - Heavy Duty

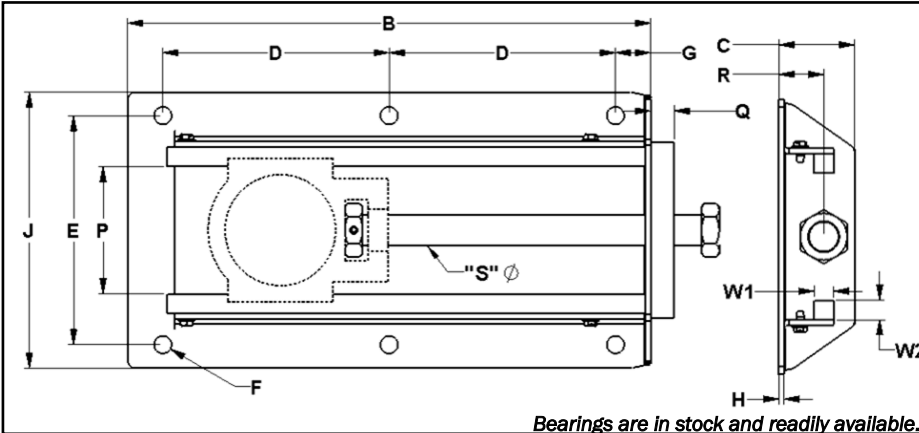

Bearings are in stock and readily available.



Available in 304 Stainless Steel construction, add "-SS" to the part number. For Example:1411HD-SS.

PCI Part#	Size	Travel	B	C	D	E	F		G	H	J	P	Q	R	S Rod Dia.	W ₁	W ₂	Approx. Weight (lbs)	Optional Cover
							No.	Bolt Dia.											
1411HD	100	1 1/2	7 1/2	1 3/4	5 3/8	5 9/16	4	1/2	1	3/16	6 9/16	3 1/16	1/2	1 1/16	5/8	1/2	1/2	4.4	1411C
1412HD		3	9		6 7/8													5	1412C
1413HD		6	12		4 15/16													6.4	1413C
1414HD		9	15		6 7/16													7.7	1414C
1415HD		12	18		7 15/16													9.1	1415C
1416HD	108	3	9 1/8	2	6 7/16	6 1/16	4	1/2	1	3/16	7 1/16	3 9/16	1/2	1 1/4	3/4	1/2	1/2	5.8	1416C
1417HD		6	12 1/8		9 7/16													7.3	1417C
1418HD		9	15 1/8		6 7/32													8.8	1418C
1419HD		12	18 1/8		7 23/32													10.4	1419C
1420HD		18	24 1/8		10 23/32													13.5	1420C
1421HD	200	3	10 3/4	2 7/16	8 1/2	7 5/16	4	9/16	1 1/8	3/16	8 13/16	4 1/16	3/4	1 7/16	1	5/8	5/8	10.7	1421C
1422HD		6	13 3/4		11 1/2													13	1422C
1423HD		9	16 3/4		7 1/4													15	1423C
1424HD		12	19 3/4		8 3/4													18	1424C
1425HD		18	25 3/4		11 3/4													22	1425C
1426HD	208	6	14 3/4	2 5/8	12 1/2	8 5/8	4	5/8	1 1/8	3/16	10 7/16	5 3/16	1	1 1/2	1 1/4	1	1/2	16	1426C
1427HD		9	17 3/4		15 1/2													19	1427C
1428HD		12	20 3/4		9 1/4													21	1428C
1429HD		15	23 3/4		10 3/4													24	1429C
1430HD		18	26 3/4		12 1/4													26	1430C
1431HD	24	32 3/4	15 1/4	32	1431C														
1432HD	300	9	20 7/8	3 3/8	17 1/2	10 1/4	4	11/16	2 1/2	1/4	12	6	1	2	1 1/2	1	1/2	32	1432C
1433HD		12	23 7/8		10 1/4													35	1433C
1434HD		18	29 7/8		13 1/4													43	1434C
1435HD		24	35 7/8		16 1/4													51	1435C
1436HD		30	41 7/8		19 1/4													59	1436C
1437HD	308	12	23 7/8	3 3/8	10 1/4	10 13/16	6	11/16	2 1/2	1/4	12 9/16	6 9/16	1	2	1 1/2	1	1/2	36	1437C
1438HD		18	29 7/8		13 1/4													43	1438C
1439HD		24	35 7/8		16 1/4													51	1439C
1440HD		30	41 7/8		19 1/4													59	1440C

Optional Take-Up Frame Covers

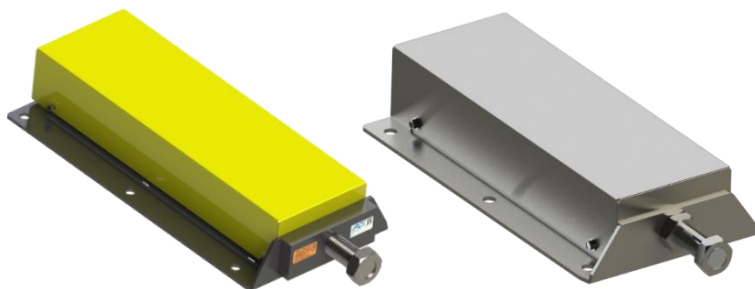

Covers

PCI Take-Up Frame covers are designed to protect internal components and are powder coated safety yellow to identify hidden moving components. To specify, add a "C" onto the part number of the corresponding frame.

For Example: 1411HD/1411HDC.

Covers are available in 304 Stainless Steel Construction. To specify Stainless Steel, add a "-SS" to the part number. For example: 1411HDC-SS.

CONVEYING COMPONENTS

Take-Up Frames

Wide Slot – Style B

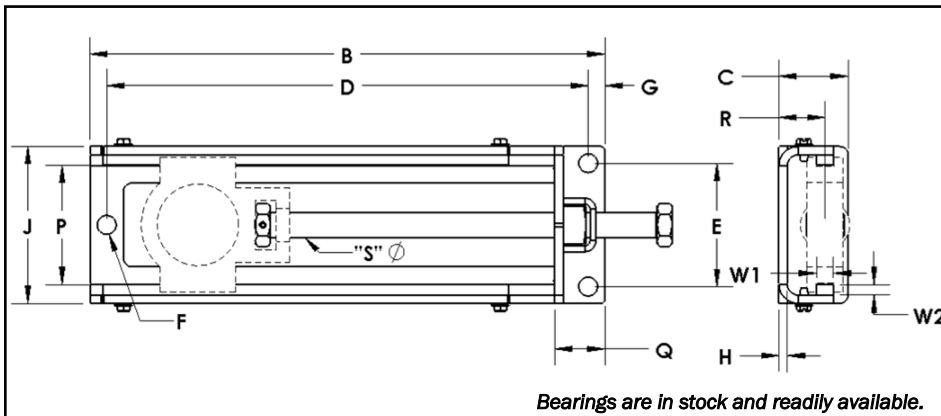

Available in 304 Stainless Steel construction, add "-SS" to the part number. For Example: 1SF10P-SS.

PCI Part#	Size	Travel	B	C	D	E	F		G	H	J	P	R	S Rod Dia.	W ₁	W ₂	Approx. Weight (lbs)	Optional Cover
							No.	Bolt Dia.										
1SF10P	100	1 1/2	7	2	6	3 3/16	3	9/16	1/2	3/16	4 1/16	3 3/32	1 3/8	5/8	1/2	5/16	3	1SF10PC
3SF16P		3	8 1/2		7 1/2												3.6	3SF16PC
6SF16P		6	11 1/2		10 1/2												4.8	6SF16PC
9SF16P		9	14 1/2		13 1/2												6.1	9SF16PC
3SF23P	108	3	9 3/8	2 1/16	8 3/8	3 11/16	3	9/16	1/2	1/4	4 11/16	3 9/16	1 3/8	3/4	1/2	5/16	5.3	3SF23PC
6SF23P		6	12 3/8		11 3/8												6.9	6SF23PC
9SF23P		9	15 3/8		14 3/8												8.5	9SF23PC
12SF23P		12	18 3/8		17 3/8												10.1	12SF23PC
3SF31P	200	3	11	2 1/2	9 7/8	3 1/16	4	9/16	1/2	1/4	5 5/16	4 1/16	1 5/8	1	5/8	3/8	8	3SF31PC
6SF31P		6	14		12 7/8												9.9	6SF31PC
9SF31P		9	17		15 7/8												12	9SF31PC
12SF31P		12	20		18 7/8												14.1	12SF31PC
18SF31P	18	26	24 7/8	18.4	18SF31PC													
9SF39P *	208	9	18 1/4	2 3/4	16 7/8	4 1/8	4	11/16	5/8	1/4	6 15/16	5 3/16	1 7/8	1 1/4	1	5/8	20.6	9SF39PC
12SF39P *		12	21 1/4		19 7/8												23.8	12SF39PC
18SF39P *		18	27 1/4		25 7/8												30.7	18SF39PC

* Size 208 Style B Frames have a 5/8" thick threaded end plate in place of the configuration shown.

Optional Take-Up Frame Covers

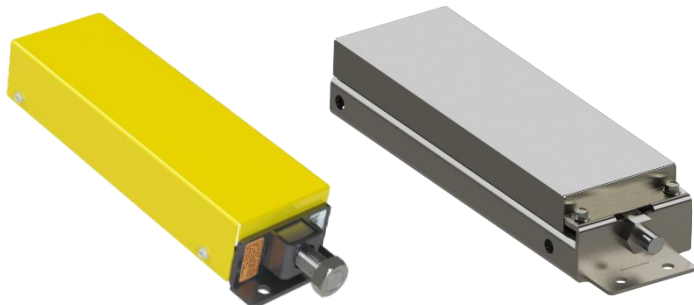

Covers

PCI Take-Up Frame covers are designed to protect internal components and are powder coated safety yellow to identify hidden moving components. To specify, add a "C" onto the part number of the corresponding frame.

For Example: 1SF10P/1SF10PC.

Covers are available in 304 Stainless Steel Construction. To specify Stainless Steel, add a "-SS" to the part number. For example: 1SF10PC-SS.

CONVEYING COMPONENTS

Take-Up Frames

Center Pull

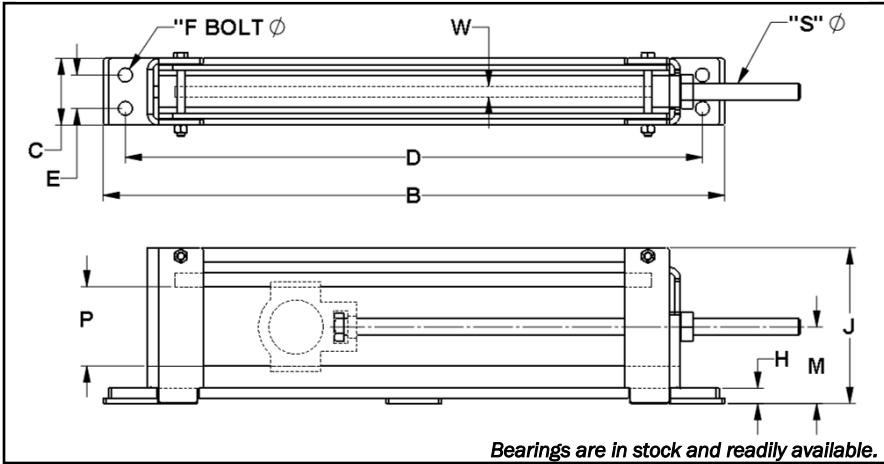

Available in 304 Stainless Steel construction, add "SS" to the part number. For Example: CP308X12TUFF-SS..

PCI Part#	Size	Nominal Travel	Max Travel	B	C	D	E	F		H	J	M	P	S Rod Dia.	W	Approx. Weight (lbs)
								No.	Bolt Dia.							
CP308X12TUFF	308	12	16 1/4	28	3	26	-	2	5/8	11/16	7	3 7/16	3 9/16	3/4	1/2	32
CP308X18TUFF		18	22 1/4	34		32										39
CP308X24TUFF		24	28 1/4	40		38										45
CP308X30TUFF		30	34 1/4	46		44										51
CP308X36TUFF		36	40 1/4	52		50										57
CP400X12TUFF	400	12	16 5/16	29 1/2	4	27 1/2	-	2	3/4	13/16	8 5/8	3 15/16	4 1/16	1	5/8	53
CP400X18TUFF		18	22 5/16	35 1/2		33 1/2										63
CP400X24TUFF		24	28 5/16	41 1/2		39 1/2										71
CP400X30TUFF		30	34 5/16	47 1/2		45 1/2										81
CP400X36TUFF		36	40 5/16	53 1/2		51 1/2										90
CP408X12TUFF	408	12	16	29 1/2	4	27 1/2	-	2	3/4	1	9 1/4	4 7/16	4 9/16	1 1/8	3/4	59
CP408X18TUFF		18	22	35 1/2		33 1/2										69
CP408X24TUFF		24	28	41 1/2		39 1/2										80
CP408X30TUFF		30	34	47 1/2		45 1/2										90
CP408X36TUFF		36	40	53 1/2		51 1/2										100
CP502X12TUFF	502	12	16 7/16	30 1/2	4	28 1/2	-	2	7/8	3/4	9 1/2	4 3/8	5 3/16	1 1/4	1	61
CP502X18TUFF		18	22 7/16	36 1/2		34 1/2										73
CP502X24TUFF		24	28 7/16	42 1/2		40 1/2										84
CP502X30TUFF		30	34 7/16	48 1/2		46 1/2										95
CP502X36TUFF		36	40 7/16	54 1/5		52 1/2										107
CP515X12TUFF	515	12	16 1/8	32 1/2	5	30 1/2	2	4	3/4	7/8	11 5/32	5 1/8	6	1 1/2	1 3/4	111
CP515X18TUFF		18	22 1/8	38 1/2		36 1/2										130
CP515X24TUFF		24	28 1/8	44 1/2		42 1/2										143
CP515X30TUFF		30	34 1/8	50 1/2		48 1/2										167
CP515X36TUFF		36	40 1/8	56 1/2		54 1/2										186
CP613X12TUFF	613	12	15 13/16	34 1/4	5	32	2	4	7/8	15/16	12 1/8	5 5/8	6 7/8	1 3/4	1 3/4	126
CP613X18TUFF		18	21 13/16	40 1/4		38										147
CP613X24TUFF		24	27 13/16	46 1/4		44										168
CP613X30TUFF		30	33 13/16	52 1/4		50										188
CP613X36TUFF		36	39 13/16	58 1/4		56										209
CP810X12TUFF	810	12	17 3/4	38 1/2	6	36	2 1/2	4	7/8	15/16	14 3/4	7	8 11/16	2	2	179
CP810X18TUFF		18	23 3/4	44 1/2		42										206
CP810X24TUFF		24	29 3/4	50 1/2		48										232
CP810X30TUFF		30	35 3/4	56 1/2		54										259
CP810X36TUFF		36	41 3/4	62 1/2		60										285
CP908X12TUFF	908	12	21	45 3/4	9	40 3/4	5	4	1 1/4	15/16	16 1/16	7 1/2	9 9/16	2	2	264
CP908X18TUFF		18	27	51 3/4		46 3/4										296
CP908X24TUFF		24	33	57 3/4		52 3/4										328
CP908X30TUFF		30	39	53 4/7		58 3/4										360
CP908X36TUFF		36	45	69 3/4		64 3/4										392
CP1004X12TUFF	1004	12	23 3/4	49 1/2	10	44 1/2	5 1/2	4	1 1/4	1 1/4	17 1/16	8 1/8	10 5/16	2 1/4	2	339
CP1004X18TUFF		18	29 3/4	55 1/2		50 1/2										376
CP1004X24TUFF		24	35 3/4	61 1/2		56 1/2										413
CP1004X30TUFF		30	41 3/4	67 1/2		62 1/2										451
CP1004X36TUFF		36	47 3/4	73 1/2		68 1/2										488

CONVEYING COMPONENTS

Take-Up Frames

Top Angle

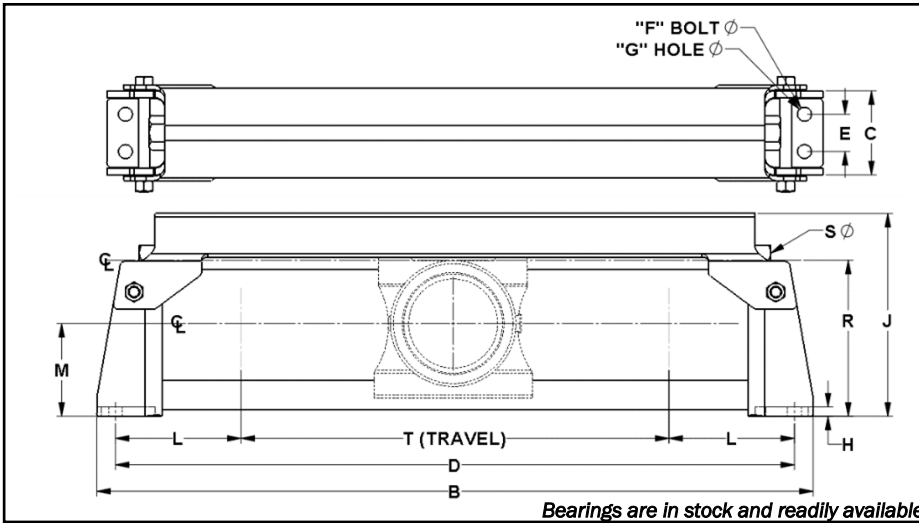

Available in 304 Stainless Steel construction, add "SS" to the part number. For Example: TP10X12TUF-SS.

PCI Part#	Size	Nominal Travel	Max Travel	B	C	D	E	F		H	J	L	M	R	S Rod Dia.	Max. Width (W)	Approx. Weight (lbs)
								No.	Bolt Dia.								
TP10X12TUF	10	12	15 1/2	28 1/2	3 1/2	26 1/2	-	2	3/4	1/2	8 1/4	5 1/2	3 15/16	6 3/8	3/4	5 1/8	36
TP10X18TUF	or 18	21 1/2	34 1/2	32 1/2		42											
TP10X24TUF	200	24	27 1/2	40 1/2	38 1/2	48											
TP20X12TUF	20	12	16	29 1/2	3 1/2	27 1/2	-	2	3/4	1/2	8 7/8	5 3/4	4 3/16	6.98	3/4	5 1/8	37
TP20X18TUF	or 18	22	35 1/2	33 1/2		43											
TP20X24TUF	203	24	28	41 1/2	39 1/2	50											
TP30X12TUF	30	12	15 1/2	30 1/2	4	28 1/2	-	2	7/8	1/2	9 7/8	6 1/2	4 3/8	7 7/16	1	5 3/4	46
TP30X18TUF	or 18	21 1/2	36 1/2	34 1/2		53											
TP30X24TUF	208	24	27 1/2	42 1/2	40 1/2	60											
TP40X12TUF	40	12	16 1/2	32 1/2	4 1/2	30 1/2	2	4	3/4	1/2	10 7/8	7	4 15/16	8 3/8	1	6 3/16	61
TP40X18TUF	or 18	22 1/2	38 1/2	36 1/2		70											
TP40X24TUF	300	24	28 1/2	44 1/2	42 1/2	79											
TP50X12TUF	50	12	16 1/2	34 1/2	4 1/2	32	2	4	7/8	1/2	12 7/16	7 3/4	5 7/16	9 1/2	1 1/4	6 1/2	66
TP50X18TUF	or 18	22 1/2	40 1/2	38		74											
TP50X24TUF	308	24	28 1/2	46 1/2	44	83											
TP60X12TUF	60	12	18	38 1/2	5 1/2	36	2 1/2	4	7/8	3/4	14 3/16	9	7	11 3/8	1 1/4	7 1/2	85
TP60X18TUF	or 18	24	44 1/2	42		94											
TP60X24TUF	400	24	30	50 1/2	48	102											

CONVEYING COMPONENTS

Take-Up Frames

Protected Screw Light Duty

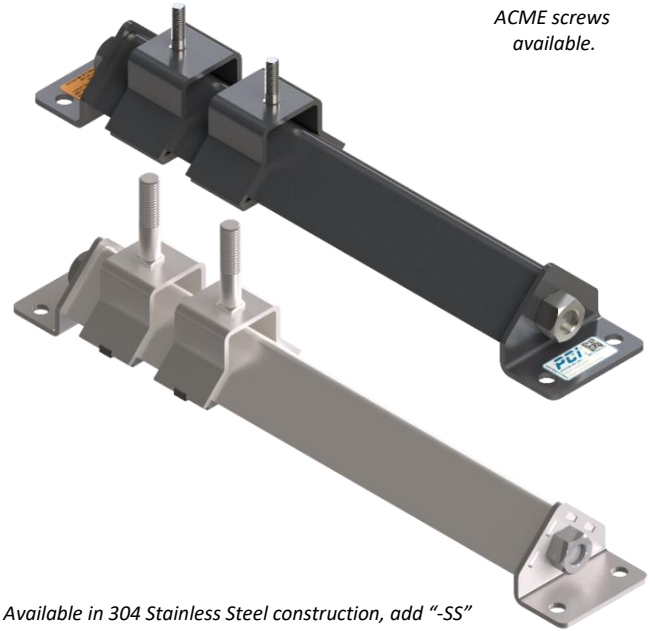
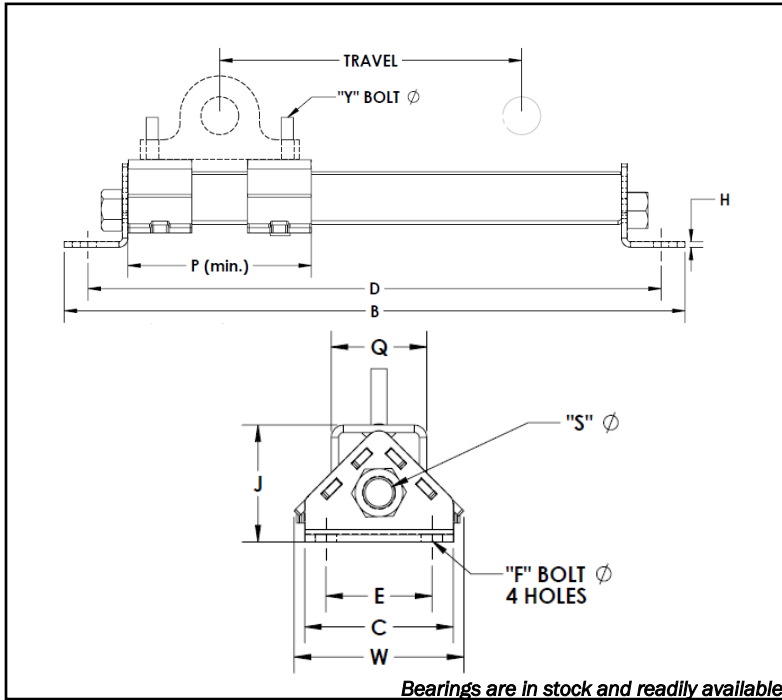

Available in 304 Stainless Steel construction, add "-SS" to the part number. For Example: LD10X12TUFF-SS.

PCI Part#	Size	Travel	B	C	D	E	F Bolt		H	J	P (Min.)	Q	S Rod Dia.	W	Y Bolt	Approx Weight (lbs)
							No.	Dia.								
LD10X6TUFF	10	6	19 1/2	3 1/2	18	2 1/2	4	1/2	3/16	2 3/4	5	2 1/4	3/4	4 1/8	3/8 x 1-1/2	9
LD10X9TUFF		9	22		20 1/2											10
LD10X12TUFF		12	25		23 1/2											11
LD10X18TUFF		18	33 1/2		32											14
LD20X6TUFF	20	6	19 1/2	3 1/2	18	2 1/2	4	1/2	3/16	2 3/4	5	2 1/4	3/4	4 1/8	1/2 x 2-1/2	9
LD20X9TUFF		9	22		20 1/2											10
LD20X12TUFF		12	25		23 1/2											11
LD20X18TUFF		18	33 1/2		32											14
LD20X24TUFF	24	39 1/2	38	16												
LD30X6TUFF	30	6	22 1/4	3 1/2	20 3/4	2 1/2	4	1/2	3/16	2 7/8	5	2 1/4	3/4	4 1/8	5/8 x 3	10
LD30X12TUFF		12	28 1/4		26 3/4											12
LD30X18TUFF		18	34 1/4		32 3/4											14
LD30X24TUFF		24	40 1/4		38 3/4											16
LD30X30TUFF	30	46 1/4	44 3/4	18												
LD40X6TUFF	40	6	22 1/4	4 1/4	20 1/2	3	4	5/8	1/4	3 3/16	6	2 3/4	3/4	4 1/2	5/8 x 3	15
LD40X12TUFF		12	28 1/4		26 1/2											18
LD40X18TUFF		18	34 1/4		32 1/2											20
LD40X24TUFF		24	40 1/4		38 1/2											23
LD40X30TUFF		30	46 1/4		44 1/2											26
LD40X36TUFF		36	52 1/4		50 1/2											29
LD45X12TUFF	45	12	33 1/4	5	31 1/2	3	4	3/4	5/16	4 1/8	7	3 1/2	1	5 1/2	3/4 x 3-1/2	33
LD45X18TUFF		18	39 1/4		37 1/2											37
LD45X24TUFF		24	45 1/4		43 1/2											42
LD45X30TUFF		30	51 1/4		49 1/2											46
LD45X36TUFF		36	57 1/4		55 1/2											50
LD45X42TUFF		42	63 1/4		61 1/2											55
LD45X48TUFF	48	69 1/4	67 1/2	59												
LD50X12TUFF	50	12	33 1/4	5	31 1/2	3	4	3/4	5/16	4 1/4	7	3 1/2	1	5 1/2	7/8 x 4	33
LD50X18TUFF		18	39 1/4		37 1/2											37
LD50X24TUFF		24	45 1/4		43 1/2											42
LD50X30TUFF		30	51 1/4		49 1/2											46
LD50X36TUFF		36	57 1/4		55 1/2											51
LD50X42TUFF		42	63 1/4		61 1/2											55
LD50X48TUFF	48	69 1/4	67 1/2	59												

CONVEYING COMPONENTS

Take-Up Frames

Protected Screw Heavy Duty

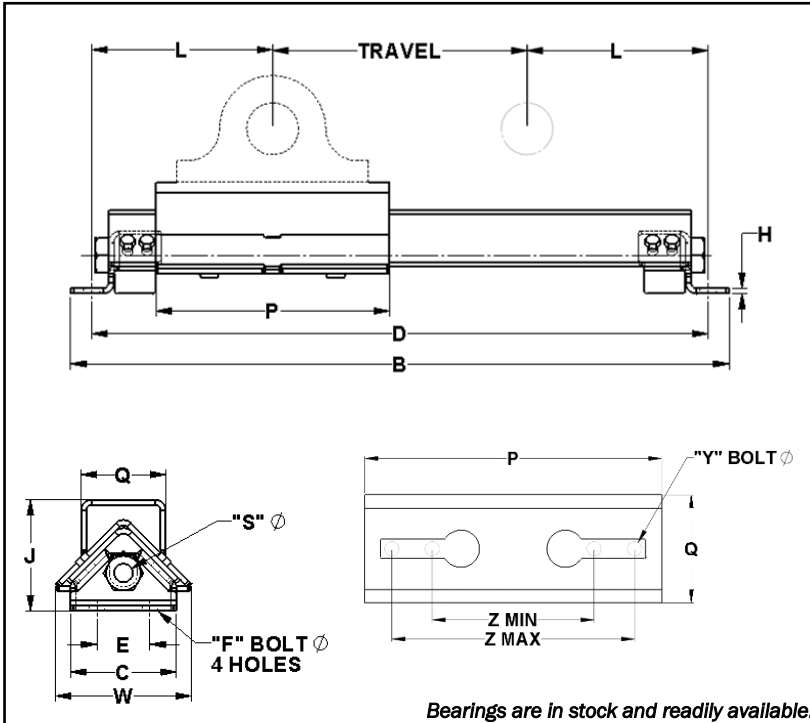

Bearings are in stock and readily available.

PCI Part#	Size	Nominal Travel	B	C	D	E	F		H	J	P	Q	S Rod Dia.	W	Y	Z		Approx. Weight (lbs)
							No.	Bolt Dia.								Min	Max	
HD200X 12T UFP	200 or 20	12	31	5	29	2 1/2	4	3/4	1/4	5 1/4	11	4	1	6 3/8	5/8	5 15/16	9 1/16	44
HD200X 18T UFP		18	37		35													48
HD200X 24T UFP		24	43		41													53
HD200X 30T UFP		30	49		47													57
HD200X 36T UFP		36	55		53													61
HD200X 48T UFP		48	67		65													70
HD250X 12T UFP	250 or 25	12	35 1/4	5 1/2	32 3/4	3	4	3/4	3/8	6 1/4	13 1/4	5	1	7 7/16	3/4	7 5/8	10 7/8	78
HD250X 18T UFP		18	41 1/4		38 3/4													84
HD250X 24T UFP		24	47 1/4		44 3/4													91
HD250X 30T UFP		30	53 1/4		50 3/4													97
HD250X 36T UFP		36	59 1/4		56 3/4													103
HD250X 48T UFP		48	71 1/4		68 3/4													116
HD300X 12T UFP	300 or 30	12	38 1/4	6 1/2	35 1/2	3	4	7/8	3/8	7	14 1/4	6	1 1/4	8 15/16	3/4	9 1/4	11 5/8	134
HD300X 18T UFP		18	44 1/4		41 1/2													143
HD300X 24T UFP		24	50 1/4		47 1/2													153
HD300X 30T UFP		30	56 1/4		53 1/2													163
HD300X 36T UFP		36	62 1/4		59 1/2													173
HD300X 48T UFP		48	74 1/4		71 1/2													193
HD350X 12T UFP	350 or 35	12	40	6 1/2	37 1/4	3	4	7/8	3/8	7	16	6	1 1/4	8 15/16	7/8	10 3/4	13 11/16	144
HD350X 18T UFP		18	46		43 1/4													154
HD350X 24T UFP		24	52		49 1/4													164
HD350X 30T UFP		30	58		55 1/4													174
HD350X 36T UFP		36	64		61 1/4													183
HD350X 48T UFP		48	76		73 1/4													203
HD400X 12T UFP	400 or 40	12	44	6 1/2	41 1/4	3	4	7/8	3/8	7	20	7 1/4	1 1/4	8 15/16	-	-	-	176
HD400X 18T UFP		18	50		47 1/4													186
HD400X 24T UFP		24	56		53 1/4													196
HD400X 30T UFP		30	62		59 1/4													206
HD400X 36T UFP		36	68		65 1/4													216
HD400X 48T UFP		48	80		77 1/4													236
HD400X 60T UFP	60	92	89 1/4	256														

PCI Heavy Duty Protected Screw Take-Up Frames through Size 350 are pre-drilled for use with 2-bolt pillow block bearing units but may be modified to allow for 4-bolt style bearings upon request. Size 400 frames are only available as drilled to customer specification.



(989)358-6149

www.pcimfg.com

CONVEYING COMPONENTS

Take-Up Frames

Telescoping - Standard Duty

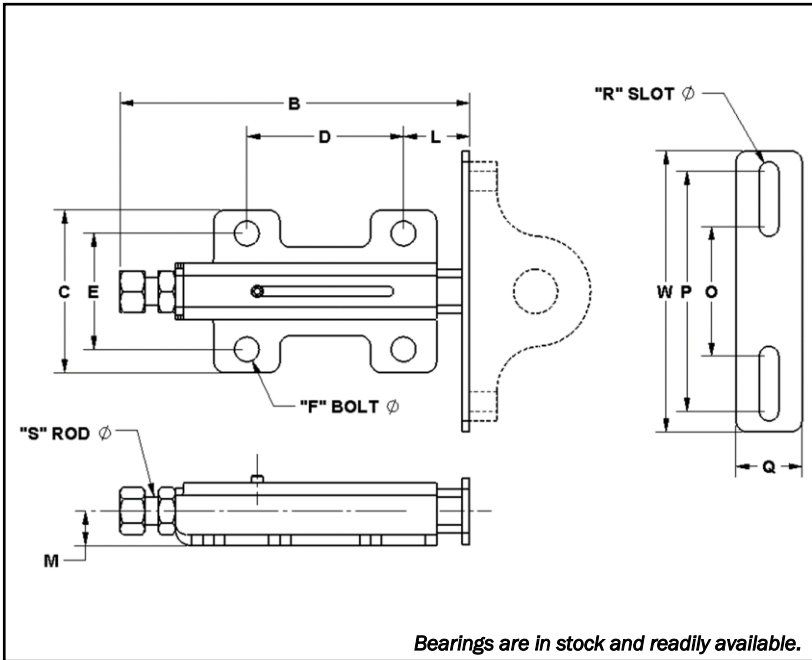

Bearings are in stock and readily available.



Carbon Steel Telescoping models include a dual purpose indicator pin/reube fitting as well as ACME screws.

Available in 304 Stainless Steel construction, add "-SS" to the part number. For Example: TS100X12TUFPP-SS.

PCI Part#	Size	Travel	B	C	D	E	F		L	M	O	P	Q	R Slot Dia.	S Rod Dia.	W	Approx. Weight (lbs)
							No.	Bolt Dia.									
TS100X3TUFPP	100	3	8 3/16	3 11/16	3 9/16	2 5/8	4	1/2	1 1/2	0.78	2 15/16	5 7/16	1 1/2	7/16	0.625	6 3/8	3
TS100X6TUFPP		6	11 11/16		7 1/16												5
TS100X9TUFPP		9	15 11/16		11 1/16												7
TS250X3TUFPP	250	3	9 3/8	4	4 3/8	3	4	1/2	1 5/8	1	3 13/16	5 11/16	2	5/8	0.75	7	6
TS250X6TUFPP		6	12 3/8		7 3/8												8
TS250X9TUFPP		9	15 3/8		10 3/8												10
TS250X12TUFPP		12	18 3/8		13 3/8												13
TS300X6TUFPP	300	6	14 1/8	5 1/4	6 1/8	4	4	5/8	1 7/8	1 3/8	5 9/16	8 11/16	2 3/4	3/4	1	10	16
TS300X9TUFPP		9	18 1/8		10 1/8												21
TS300X12TUFPP		12	22 1/8		14 1/8												26
TS300X18TUFPP		18	29 1/8		21 1/8												34
TS300X24TUFPP		24	35 1/8		27 1/8												41
TS300X36TUFPP		24	47 1/8		39 1/8												55
TS325X6TUFPP-SS	325	6	12 3/4	5 1/4	7 1/8	4	4	5/8	1 7/8	1.30	5 9/16	8 11/16	2.84	11/16	1	10	17
TS325X9TUFPP-SS		9	15 3/4		10 1/8												21
TS325X12TUFPP-SS		12	18 3/4		13 1/8												25
TS325X18TUFPP-SS		18	24 3/4		19 1/8												33
TS350X6TUFPP	350	6	16	6	9 5/8	4 1/2	4	5/8	1 7/8	1 1/2	5 9/16	8 11/16	3	3/4	1	10	23
TS350X9TUFPP		9	19		12 5/8												28
TS350X12TUFPP		12	22		15 5/8												33
TS350X18TUFPP		18	28		21 5/8												43
TS350X24TUFPP		24	34		27 5/8												53
TS400X6TUFPP	400	6	22 3/4	7 1/2	14	5 1/2	4	7/8	3 1/2	1.92	8 1/2	11 3/4	3 1/2	7/8	1.5	14	48
TS400X9TUFPP		9	25 3/4		17												55
TS400X12TUFPP		12	28 3/4		20												61
TS400X18TUFPP		18	34 3/4		26												74
TS400X24TUFPP		24	40 3/4		32												87
TS400X36TUFPP		36	52 3/4		44												113
TS400X48TUFPP		48	64 3/4		56												138
TS500X18TUFPP		500	18		43 7/8												11 1/2
TS500X24TUFPP	24		49 7/8	37	255												
TS500X36TUFPP	36		61 7/8	49	318												

TS325 units available in Stainless Steel construction only.
 TS300, TS400 and TS500 units available in Carbon Steel construction only.

CONVEYING COMPONENTS

Focus Flyer – Take-up Frames

Telescoping – Tension Indicating



Take-Up Frames are utilized on conveyor systems to promote belt tracking and prevent belt slippage by maintaining proper belt tension on both extensions of a tail/take-up pulley. PCI® Tension Indicating Take-Up Frames utilize spring pressure to help maintain belt tension and automatically adjust for belt stretch and sudden load changes. Another feature, exclusive to PCI, is the tension indicating scale, which provides a real time readout of the belt tension-to help you *take the tension out of belt tensioning and tracking!*

DESIGN BENEFITS

*Real-time Belt Tension Readout
Offers Optimum Tracking and
Monitoring*

*Enables Quick and Easy Installment
for Rapid Set-up Duplication*

*Displays Available Amount of
Adjustment Left on the Take-Up
Frame*

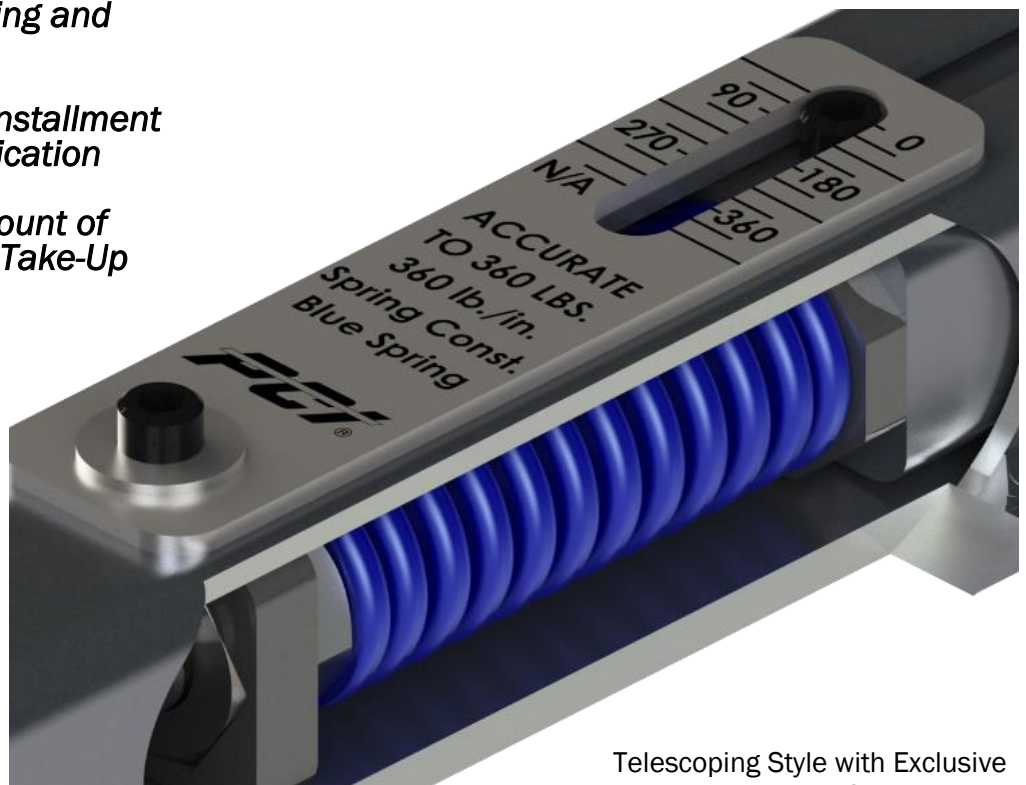

Telescoping Style with Exclusive Tension Indicating Scale (enlarged cut-a-way view shown)

Tension Indicating Take-Up Frame Styles Available



Narrow Slot



Wide Slot



Wide Slot -B



Telescoping



(989)358-6149

www.pcimfg.com

CONVEYING COMPONENTS

Focus Flyer – Take-up Frames Telescoping – Tension Indicating



How is the PCI® Tension Indicating Take-Up Frame different from other Frames?

PCI Tension Indicating Take-Up Frames help you *take the tension out of belt tensioning and tracking* by providing an actual “real-time” readout along with the amount of belt tension adjustment available, which enables an installer to record the optimum belt tension for reliable belt tracking. PCI utilizes premium die springs which provide long life, and consistent accuracy. Maintenance personnel can continuously monitor and re-adjust belt tension during normal operation, when changing out critical system components, or during set up of duplicate conveyor systems.

Feature	 Tension Indicating Telescoping Take-Up Frames	Competitive Spring Loaded Telescoping Take-Up Frames
Spring pressure accommodates for belt stretch over time.	✓	✓
Maintains belt tension in extreme hot or cold conditions by accommodating for thermal expansion and contraction of belts.	✓	✓
Improves the accuracy of belt scales by reducing the counter-effects of belt tension on scale readings.	✓	✓
Acts as a shock absorber, protecting the take-up pulley and belt from shock loading caused by sudden starts/stops, impacts, or debris between the belt and pulley.	✓	✓
Provides an actual real-time readout of belt tension.	✓	✗
Enables an installer to record the optimum belt tension for reliable belt tracking.	✓	✗
Allows maintenance personnel to continuously monitor belt tension, and re-adjust to optimum quickly and easily.	✓	✗
Allows users to quickly and easily adjust the belt to the optimum tension when changing out a belt, pulley, or any other conveyor components.	✓	✗
Enables rapid set up of duplicate conveyor systems by quickly adjusting the take-ups to the pre-determined optimum tension for belt tracking.	✓	✗
Utilizes premium die springs for long life and consistent accurate readout.	✓	✗
Displays to the user, the available amount of adjustment left on the take-up frame.	✓	✗

CONVEYING COMPONENTS

Side or Top Mount Take-Up Frames

Cross Reference & Bearing Selection Charts



Narrow Slot

These tables are provided to assist with bearing selection process. This information does not include all potential bearing options. Maximum and minimum bores sizes listed are an attempt to communicate the absolute limits for bore size available for a given frame style and are dependent on manufacturer design and style of bearing selected. Bearing equivalency and specifications should be reviewed to ensure compliance with take-up frame specifications. Bearing selection is the sole responsibility of the user.

Contact PCI for Bearing availability.

NS - Narrow Slot Take-Up Frame Cross Reference							
Take-Up Frame			Useable Bearings & Bore Range (Range includes .50" Min. - 2.4375" Max.)				
	Dodge		Bearing Series	Ball Bearings			
				Dodge			
				Normal Duty NSTU - SC		Medium Duty NSTU - SCM	
				Min.	Max.	Min.	Max.
1400	NS210	038109	204 - 205	1/2"	1"	-----	-----
1401 - 1402	NS308	038110 - 038111	206 - 207	1 1/16"	1 7/16"	1"	1 1/4"
1403 - 1406	NS400	038112 - 038115	208 - 209 - 210	1 1/2"	2"	1 7/16"	1 3/4"
1407 - 1408	NS407	038116 - 038117	211	2"	2 1/4"	1 15/16"	2"
1409 - 1410	NS415	038118 - 038119	212	2 1/4"	2 7/16"	2 3/16"	2 1/4"

CONVEYING COMPONENTS

Side Mount Take-Up Frames

Cross Reference & Bearing Selection Charts



Wide Slot - Standard Duty

Wide Slot - Heavy Duty

Wide Slot - Style B

These tables are provided to assist with bearing selection process. This information does not include all potential bearing options. Maximum and minimum bores sizes listed are an attempt to communicate the absolute limits for bore size available for a given frame style and are dependent on manufacturer design and style of bearing selected. Bearing equivalency and specifications should be reviewed to ensure compliance with take-up frame specifications. Bearing selection is the sole responsibility of the user.

Contact PCI for Bearing availability.

WS & WHD - Wide Slot Take-Up Frame Cross Reference								
Take-Up Frame				Useable Bearings & Bore Range (Range includes .50" Min. - 3.00" Max.)				
	Dodge	PPI	Bearing Series	Ball Bearings				
				Dodge				
				Normal Duty WSTU - SC		Medium Duty WSTU - SCM		
				Min.	Max.	Min.	Max.	
1411 - 1415	WS300	038200 - 038204	PWS-100	204 - 205	1/2"	1"	-----	-----
1416 - 1420	WS308	038205 - 038209	PWS-108	206 - 207	1 1/16"	1 7/16"	1"	1 1/4"
1421 - 1425	WS400	038210 - 038214	PWS-200	208 - 209 - 210	1 1/2"	2"	1 7/16"	1 3/4"
1426 - 1431	WS502	038215 - 038220	PWS-208	211 - 212	2"	2 7/16"	1 15/16"	2 1/4"
1432 - 1436	WS515	038221 - 038225	PWS-300	214 - 215	2 1/2"	2 15/16"	2 7/16"	2 11/16"
1437 - 1440	WS608	038226 - 038229	PWS-308	216	-----	-----	2 15/16"	3"

WS Style B - Wide Slot Take-Up Frame Cross Reference								
Take-Up Frame				Useable Bearings & Bore Range (Range includes .50" Min. - 3.00" Max.)				
	Browning (Regal Beloit)	Hub City (Regal Beloit)	Bearing Series	Ball Bearings				
				Dodge				
				Normal Duty WSTU - SC		Medium Duty WSTU - SCM		
				Min.	Max.	Min.	Max.	
1SF10P - 9SF16P	1SF10 - 9SF16	1TWS200AC - 9TWS200AC	204 - 205	1/2"	1"	-----	-----	
3SF23P - 12SF23P	3SF23 - 12SF23	3TWS200DE - 12TWS200DE	206 - 207	1 1/16"	1 7/16"	1"	1 1/4"	
3SF31P - 18SF31P	3SF31 - 18SF31	3TWS200FH - 18TWS200FH	208 - 209 - 210	1 1/2"	2"	1 7/16"	1 3/4"	
9SF39P - 18SF39P	9SF39 - 18SF39	9TWS200JK - 18TWS200JK	211 - 212	2"	2 7/16"	1 15/16"	2 1/4"	

CONVEYING COMPONENTS

Top Mount Take-Up Frames

Cross Reference & Bearing Selection Charts



Center Pull

These tables are provided to assist with bearing selection process. This information does not include all potential bearing options. Maximum and minimum bores sizes listed are an attempt to communicate the absolute limits for bore size available for a given frame style and are dependent on manufacturer design and style of bearing selected. Bearing equivalency and specifications should be reviewed to ensure compliance with take-up frame specifications. Bearing selection is the sole responsibility of the user.

Contact PCI for Bearing availability.

CP - Center Pull Take-Up Frame Cross Reference								
Take-Up Frame			Useable Bearings & Bore Range (Range includes 1.125" Min. - 4.9375" Max.)					
PCI	Dodge	PPI	Spherical Roller Bearings				Tapered Roller Bearings	
			Dodge					
			Imperial WSTU		WSTU S2 S-2000		WSTU TYPE K / TYPE E	
			Min.	Max.	Min.	Max.	Min.	Max.
CP308	CP308	PCP108	1 1/8"	1 1/2"	1 3/8"	1 1/2"	1 3/8"	1 7/16"
CP400	CP400	PCP200	1 5/8"	2"	1 11/16"	2"	1 1/2"	2"
CP408	CP408	PCP203	2 3/16"	2 1/4"	-----	2 3/16"	-----	2 3/16"
CP502	CP502	PCP208	2 3/8"	2 1/2"	-----	2 7/16"	2 1/4"	2 1/2"
CP515	CP515	PCP300	2 11/16"	3"	2 11/16"	3"	2 11/16"	3"
CP613	CP613	PCP308	3 3/16"	3 1/2"	-----	3 7/16"	-----	-----
CP810	CP810	PCP400	3 11/16"	4"	-----	3 15/16"	-----	-----
CP908	CP908	PCP408	-----	-----	-----	4 7/16"	-----	-----
CP1004	CP1004	PCP500	-----	-----	-----	4 15/16"	-----	-----

CONVEYING COMPONENTS

Top Mount Take-Up Frames

Cross Reference & Bearing Selection Charts



Top Angle

These tables are provided to assist with bearing selection process. This information does not include all potential bearing options. Maximum and minimum bores sizes listed are an attempt to communicate the absolute limits for bore size available for a given frame style and are dependent on manufacturer design and style of bearing selected. Bearing equivalency and specifications should be reviewed to ensure compliance with take-up frame specifications. Bearing selection is the sole responsibility of the user.

Contact PCI for Bearing availability.

TP - Top Angle Take-Up Frame Cross Reference										
Take-Up Frame			Useable Bearings & Bore Range (Range includes 1.6875" Min. - 4.00" Max.)							
PCI	Dodge	PPI	Ball Bearings				Spherical Roller Bearings		Tapered Roller Bearings	
			Dodge							
			TPTU TYPE G		TPTU TYPE GM		TPHU S-2000		TPTU TYPE K / TYPE E	
			Min.	Max.	Min.	Max.	Min.	Max.	Min.	Max.
TP10	TP10	PTA200	1 15/16"	2"	1 11/16"	1 3/4"	1 15/16"	2"	1 3/4"	2"
TP20	TP20	PTA203	2"	2 1/4"	1 15/16"	2"	-----	-----	-----	2 3/16"
TP30	TP30	PTA208	2 1/4"	2 7/16"	2 3/16"	2 1/4"	-----	2 3/16"	2 1/4"	2 1/2"
TP40	TP40	PTA300	2 1/2"	2 15/16"	2 7/16"	2 11/16"	2 7/16"	3"	2 11/16"	3"
TP50	TP50	PTA308	-----	-----	2 15/16"	3"	-----	3 7/16"	3 3/16"	3 1/2"
TP60	TP60	PTA400	-----	-----	3 7/16"	3 1/2"	-----	4 7/16"	3 15/16"	4"

CONVEYING COMPONENTS

Top Mount Take-Up Frames

Cross Reference & Bearing Selection Charts



Protected Screw – Light Duty

Protected Screw – Heavy Duty

These tables are provided to assist with bearing selection process. This information does not include all potential bearing options. Maximum and minimum bores sizes listed are an attempt to communicate the absolute limits for bore size available for a given frame style and are dependent on manufacturer design and style of bearing selected. Bearing equivalency and specifications should be reviewed to ensure compliance with take-up frame specifications. Bearing selection is the sole responsibility of the user.

Contact PCI for Bearing availability.

LD- Light Duty Protected Screw Cross Reference																		
Take-Up Frame			Useable Bearings & Maximum Bore (range includes .50" Min - 3.50" Max)															
PCI	Dodge	PPI	Ball Bearings								Roller Bearings							
			Dodge				SKF				Dodge			SKF				
			SC		SCM		SY		SYM		S-2000		Type E		SYR		SYE	
			Min.	Max.	Min.	Max.	Min.	Max.	Min.	Max.	Min.	Max.	Min.	Max.	Min.	Max.	Min.	Max.
LD10	LD10	PLD100	1/2"	15/16"	-----	-----	1/2"	7/8"	-----	-----	-----	1 3/16"	1 1/4"	-----	-----	-----	-----	
LD20	LD20	PLD108	1 1/16"	1 3/4"	1"	1 1/2"	1 1/16"	1 3/4"	1"	1 1/2"	1 3/8"	1 3/4"	1 3/8"	1 11/16"	1 7/16"	1 1/2"	-----	
LD30	LD30	PLD200	1 15/16"	2"	1 11/16"	1 3/4"	-----	1 15/16"	1 11/16"	1 3/4"	1 15/16"	2"	-----	-----	-----	-----	-----	
LD40	LD40	PLD208	2"	2 7/16"	1 15/16"	2 1/4"	2"	2 7/16"	1- 1/16"	2 3/16"	2 3/16"	2 7/16"	1 3/4"	2 1/2"	2 3/16"	2 1/2"	1 1/2"	2 3/16"
LD45	LD45	PLD300	2 1/2"	2 11/16"	2 7/16"	2 1/2"	2 1/2"	2 15/16"	2 7/16"	2 1/2"	2 11/16"	3"	2 11/16"	3 1/2"	2 11/16"	3"	2 7/16"	3"
LD50	LD50	PLD308	-----	2 15/16"	2 11/16"	3 1/2"	-----	-----	2 11/16"	3"	-----	3 7/16"	3 3/16"	3 1/2"	3 7/16"	3 1/2"	3 7/16"	3 1/2"

HD - Heavy Duty Protected Screw Take-Up Frame Cross Reference																	
Take-Up Frame			Useable Bearings & Maximum Bore (range includes 1.4375" Min - 5.00" Max)														
PCI	Dodge	PPI	Ball Bearings		Spherical Roller Bearings						Tapered Roller Bearings						
			SKF						Dodge								
			SYM (P2BM)		SYE (P2BE)		SAF 22500		S-2000		USAF 500		TAF		Type K / Type E Extra		
			Min.	Max.	Min.	Max.	Min.	Max.	Min.	Max.	Min.	Max.	Min.	Max.	Min.	Max.	
HD200	HD200	PHD200	1 11/16"	2 3/16"	1 1/2"	2 1/2"	1 13/16"	2 1/2"	1 3/8"	2 11/16"	1 15/16"	2 3/16"	2 7/16"	2 1/2"	1 1/2"	2 1/2"	
HD250	HD250	PHD208	2 7/16"	3"	2 11/16"	3"	2 5/8"	3 1/4"	2 15/16"	3"	2 7/16"	3"	2 15/16"	3"	2 11/16"	3"	
HD300	HD300	PHD300	-----	-----	2 11/16"	3"	2 5/8"	3 1/4"	-----	3 7/16"	-----	3 3/16"	2 15/16"	3"	2 11/16"	3"	
HD350	HD350	PHD308	-----	-----	3 3/16"	3 1/2"	3 5/16"	3 1/2"	3 15/16"	4 7/16"	3 7/16"	3 1/2"	3 7/16"	4"	3 3/16"	3 1/2"	
HD400	HD400	PHD400	-----	-----	-----	-----	-----	4 7/16"	-----	4 15/16"	3 15/16"	4 1/2"	4 7/16"	5"	3 15/16"	5"	

CONVEYING COMPONENTS

Side or End Mount Take-Up Frames

Cross Reference & Bearing Selection Charts

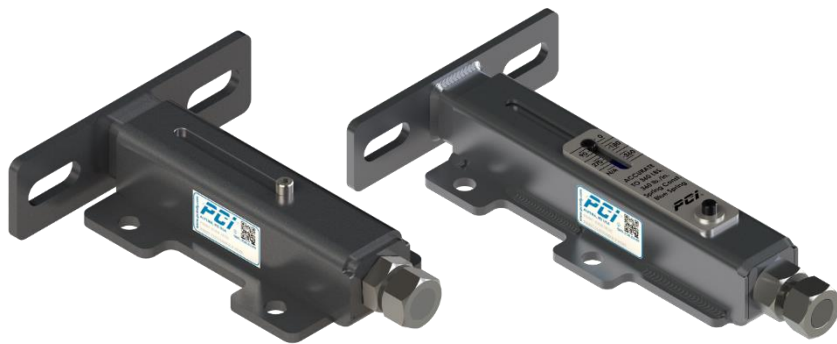

Telescoping

Telescoping – Tension Indicating

These tables are provided to assist with bearing selection process. This information does not include all potential bearing options. Maximum and minimum bores sizes listed are an attempt to communicate the absolute limits for bore size available for a given frame style and are dependent on manufacturer design and style of bearing selected. Bearing equivalency and specifications should be reviewed to ensure compliance with take-up frame specifications. Bearing selection is the sole responsibility of the user.

Contact PCI for Bearing availability.

TS- Telescoping Take-Up Frame Cross Reference																		
Take-Up Frame			Useable Bearings & Maximum Bore (range includes 1.0625" Min - 6.00" Max)															
PCI	Bryant	PPI	Ball Bearings								Roller Bearings							
			Dodge				SKF				Dodge				SKF			
			SC		SCM		SY		SYM		S-2000		TYPE E / TYPE K		SYR		SYE	
			Min.	Max.	Min.	Max.	Min.	Max.	Min.	Max.	Min.	Max.	Min.	Max.	Min.	Max.	Min.	Max.
TS100	100	N/A	1/2"	1"	-----	-----	1/2"	1"	-----	-----	-----	-----	-----	-----	-----	-----	-----	
TS250	250	PST250	1 1/16"	1 3/4"	1"	1 1/2"	1 1/16"	1 7/16"	1"	1 3/16"	1 3/8"	1 1/2"	1 3/16"	1 7/16"	1 7/16"	1 1/2"	-----	
TS300	300	PST300	1 15/16"	2 11/16"	1 11/16"	2 1/2"	1 1/2"	2 7/16"	1 7/16"	2 3/16"	1 11/16"	2 3/16"	1 3/8"	2 3/16"	1 11/16"	2 1/2"	1 7/16"	2 3/16"
TS350	350HD	PST350	-----	2 15/16"	2 11/16"	3"	1 1/2"	2 7/16"	1 7/16"	2 3/16"	2-7/16"	3"	2 1/4"	2 1/2"	1 11/16"	3"	1 7/16"	2 3/16"
TS400	400	PST400	-----	2 15/16"	2 15/16"	3"	2 1/2"	2 15/16"	2 7/16"	3"	-----	3 7/16"	2 11/16"	3 1/2"	3 7/16"	3 1/2"	3 7/16"	3 1/2"
TS500	500	PST500	-----	-----	-----	-----	-----	-----	-----	-----	-----	3 15/16"	4 15/16"	3 3/16"	5"	3 15/16"	4"	-----



Solutions Through Innovation

STAINLESS STEEL HUBS & BUSHINGS

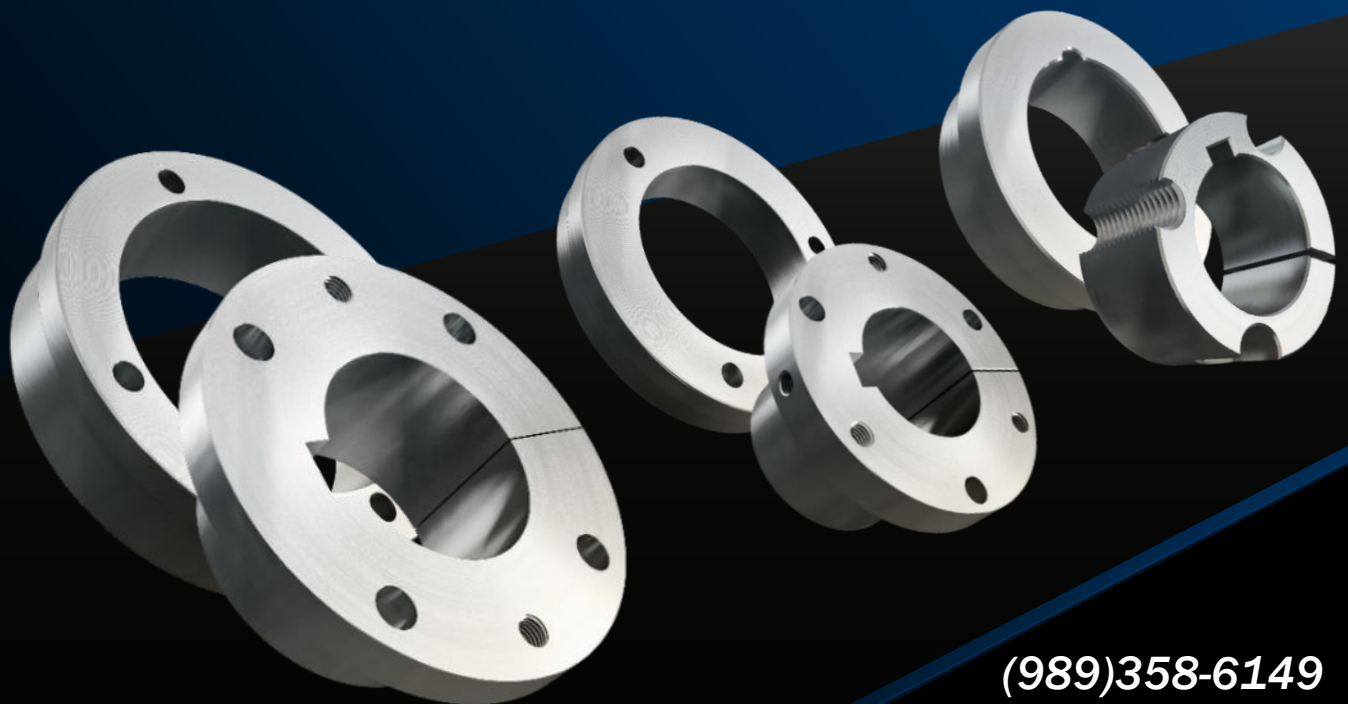

(989)358-6149
www.pcimfg.com

ACCESSORIES

Stainless Steel Compression Hubs & Bushings XT® Style

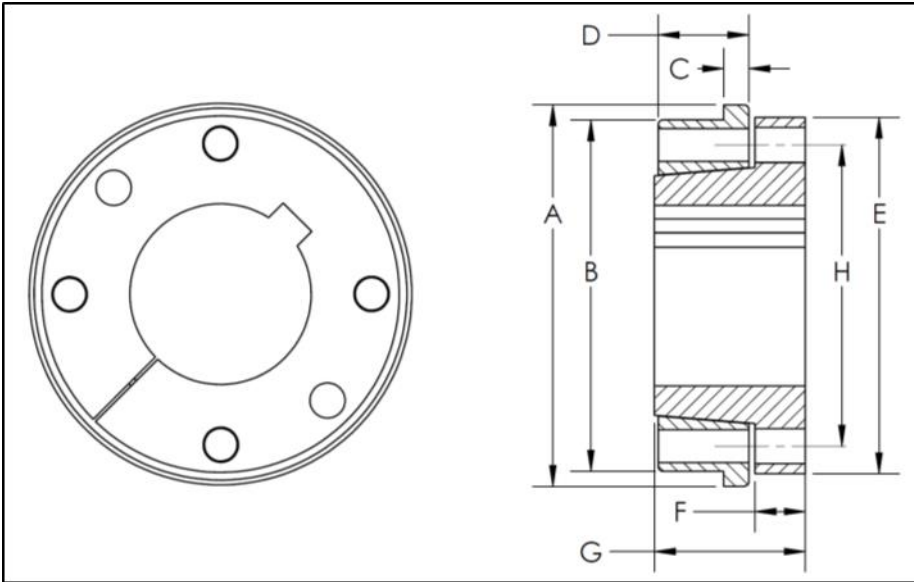

Precision Machined 300 Series Stainless Steel
2" Taper per Foot
Stock Availability
Inch and Metric Bore Sizes
Made in the USA

Hub Bushing	HUB SPECIFICATIONS				BUSHING SPECIFICATIONS								
	A	B	C	D	E	F	G	H	# of Bolts	Bolt Size	Maximum Bolt Torque (in/lbs)	Maximum Bore	
	Flange Dia.	Pilot Dia.	Flange Width	Total Length	Flange Dia.	Flange Width	Total Length	Bolt Circle				inch	mm
XT15	3.250	2.875	0.188	0.625	2.875	0.375	1.125	2.438	4	1/4	75	1-1/2	35
XT20	4.125	3.813	0.250	0.813	3.750	0.469	1.406	3.188	4	5/16	130	2	50
XT25	4.750	4.375	0.313	1.125	4.438	0.625	1.875	3.750	4	3/8	230	2-1/2	65
XT30	6.000	5.750	0.375	1.250	5.313	0.688	2.063	4.563	4	7/16	370	3	75
XT35	6.625	6.344	0.438	1.500	6.313	0.781	2.469	5.438	4	1/2	510	3-1/2	90
XT40	7.625	7.250	0.500	1.750	7.125	0.875	2.818	6.125	4	9/16	680	4	100
XT45	8.375	8.000	0.625	2.125	8.000	0.938	3.313	6.875	4	5/8	1110	4-1/2	110
XT50	10.000	9.563	0.750	2.500	10.125	1.000	3.750	8.313	4	3/4	1530	5	125

Nomenclature

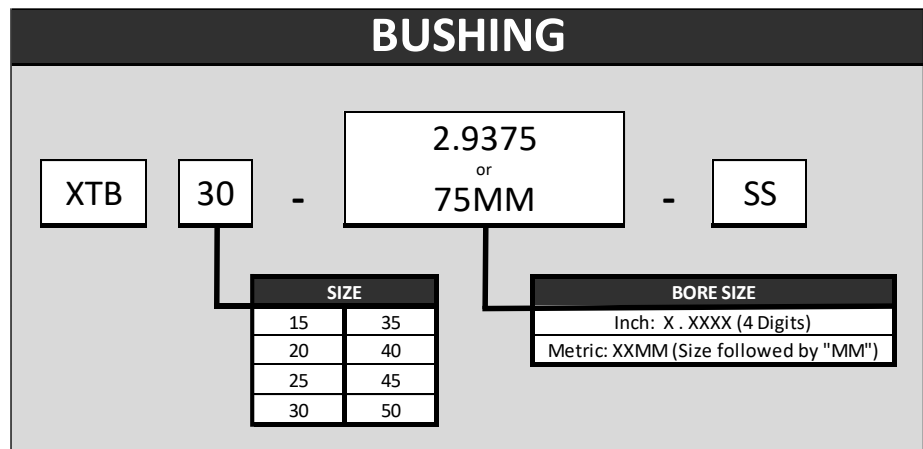
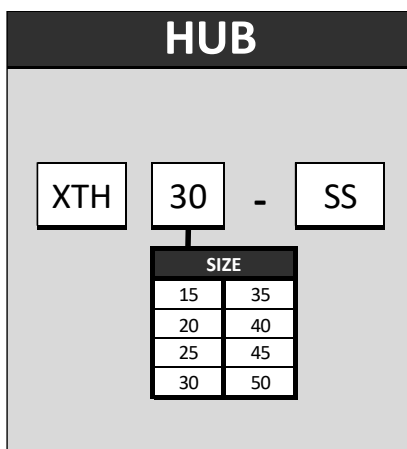

XT® is a registered trademark of Van Gorp Corp.



(989)358-6149

www.pcimfg.com

ACCESSORIES

Stainless Steel Compression Hubs & Bushings HE Style

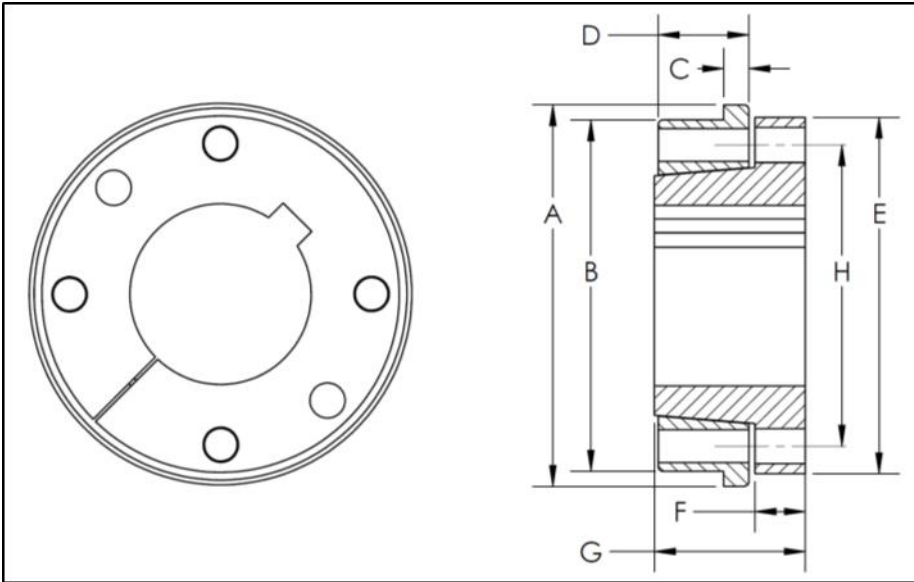

Precision Machined 300 Series Stainless Steel
3" Taper per Foot
Stock Availability
Inch and Metric Bore Sizes
Made in the USA

Hub Bushing	HUB SPECIFICATIONS				BUSHING SPECIFICATIONS								
	A	B	C	D	E	F	G	H	# of Bolts	Bolt Size	Maximum Bolt Torque (in/lbs)	Maximum Bore	
	Flange Dia.	Pilot Dia.	Flange Width	Total Length	Flange Dia.	Flange Width	Total Length	Bolt Circle				inch	mm
HE25	4.700	4.499	0.318	1.140	4.625	0.750	1.805	3.938	4	3/8	230	2-1/2	65
HE30	6.000	5.750	0.380	1.265	5.625	0.875	2.200	4.688	4	1/2	510	3	75
HE35	6.910	6.627	0.505	1.515	6.625	0.875	2.780	5.563	4	9/16	680	3-1/2	90
HE40	8.420	8.000	0.505	1.765	7.500	1.000	2.925	6.313	4	5/8	1110	4	100
HE45	9.000	8.499	0.630	2.140	8.750	1.250	3.200	7.313	6	5/8	1110	4-1/2	110
HE50	10.000	9.562	0.725	2.515	9.625	1.500	3.700	8.000	6	3/4	1530	5	125

Nomenclature

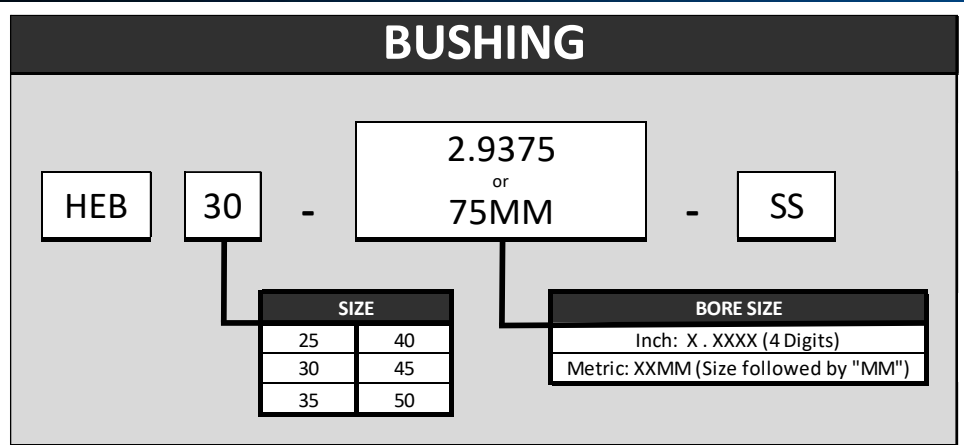
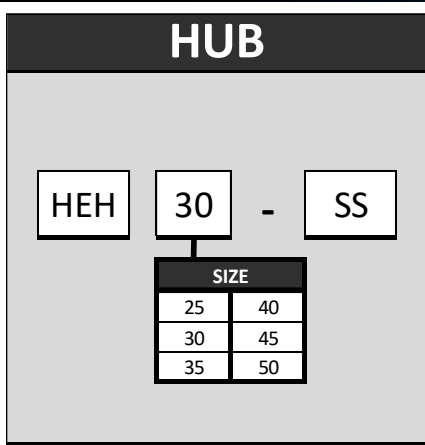

(989)358-6149

www.pcimfg.com

ACCESSORIES

Stainless Steel Compression Hubs & Bushings QD® Style

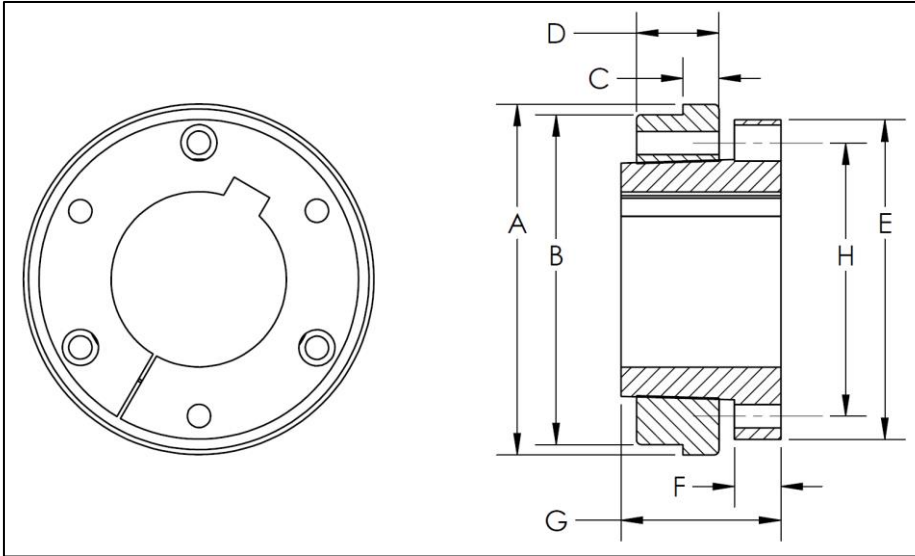

Precision Machined 300 Series Stainless Steel
3/4" Taper per Foot
Stock Availability
Inch and Metric Bore Sizes
Made in the USA

Hub Bushing	HUB SPECIFICATIONS				BUSHING SPECIFICATIONS								
	A	B	C	D	E	F	G	H	# of Bolts	Bolt Size	Maximum Bolt Torque (in/lbs)	Maximum Bore	
	Flange Dia.	Pilot Dia.	Flange Width	Total Length	Flange Dia.	Flange Width	Total Length	Bolt Circle				inch	mm
JA	2.313	2.125	0.375	0.563	2.000	0.313	1.000	1.656	3	10-24	20	1-1/4	25
SH	3.125	2.875	0.500	0.813	2.625	0.438	1.313	2.250	3	1/4	75	1-11/16	35
SDS	3.625	3.375	0.438	0.750	3.125	0.438	1.313	2.688	3	1/4	75	2	40
SK	4.250	4.000	0.438	1.000	3.875	0.563	1.938	3.313	3	5/16	130	2/5/8	55
SF	5.000	4.750	0.438	1.000	4.625	0.625	2.063	3.875	3	3/8	230	2-15/16	60
E	6.250	6.000	0.500	1.125	6.000	0.875	2.750	5.000	3	1/2	510	3-1/2	75
F	7.000	6.750	0.563	1.250	6.625	1.000	3.750	5.625	3	9/16	680	4	90
JS	8.250	8.000	0.625	1.625	7.250	1.000	3.375	6.250	3	5/8	1110	4-1/2	110
MS	9.500	9.250	0.750	2.370	9.000	1.188	4.813	7.875	4	3/4	1530	5-1/2	120

Nomenclature

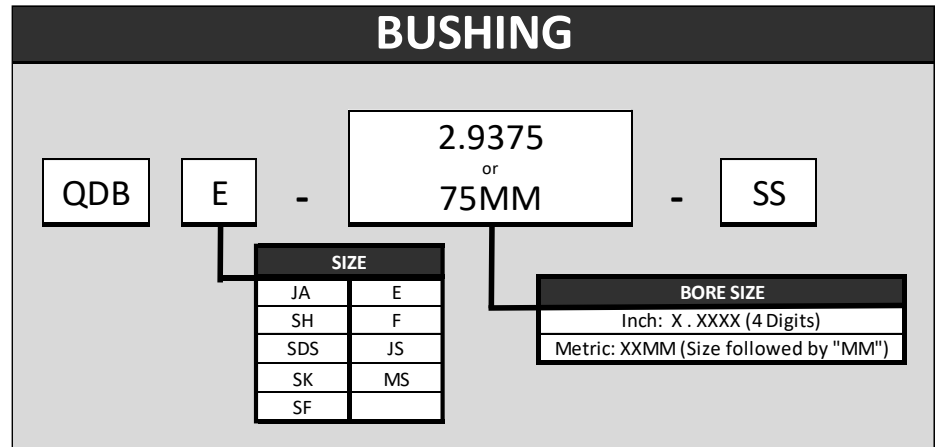
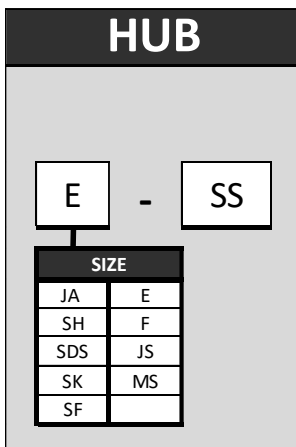

QD® is a registered trademark of Emerson Electric Corp.



(989)358-6149

www.pcimfg.com

ACCESSORIES

Stainless Steel Compression Hubs & Bushings Taper-Lock® Style

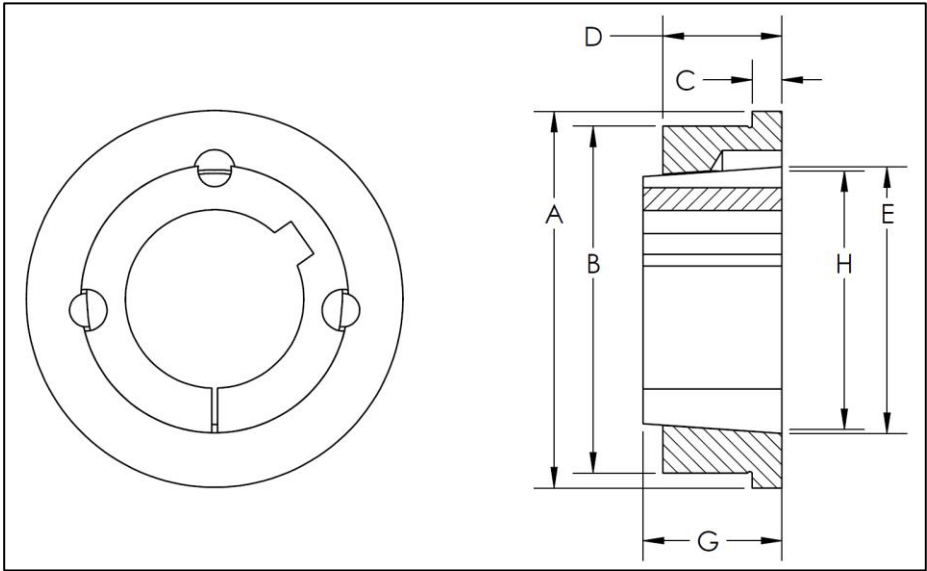

Precision Machined 300 Series Stainless Steel
1-11/16" Taper per Foot
Stock Availability
Inch and Metric Bore Sizes
Made in the USA

Hub Bushing	HUB SPECIFICATIONS				BUSHING SPECIFICATIONS							
	A	B	C	D	E	G	H	# of Bolts	Bolt Size	Maximum Bolt Torque (in/lbs)	Maximum Bore	
	Flange Dia.	Pilot Dia.	Flange Width	Total Length	Bushing Dia.	Total Length	Bolt Circle				inch	mm
1210	2.875	2.500	0.313	0.875	1.875	1.000	1.750	2	3/8	115	1-1/4	30
1610	3.250	2.875	0.313	0.875	2.250	1.000	2.125	2	3/8	115	1-11/16	40
2012	3.750	3.438	0.313	1.000	2.750	1.250	2.625	2	7/16	185	2	45
2517	4.750	4.375	0.375	1.500	3.375	1.750	3.250	2	1/2	255	2-1/2	65
3020	5.500	5.125	0.375	1.625	4.250	2.000	4.000	2	5/8	555	3	75
3535	6.750	6.250	0.500	1.625	5.000	3.500	4.828	3	1/2	700	3-1/2	90
4040	7.750	7.250	0.500	2.125	5.750	4.000	5.548	3	5/8	1110	4	100
4545	8.500	8.000	0.625	2.625	6.375	4.500	6.125	3	3/4	1520	4-1/2	115
5050	9.250	8.750	0.625	2.875	7.000	5.000	6.719	3	7/8	1930	5	125

Nomenclature

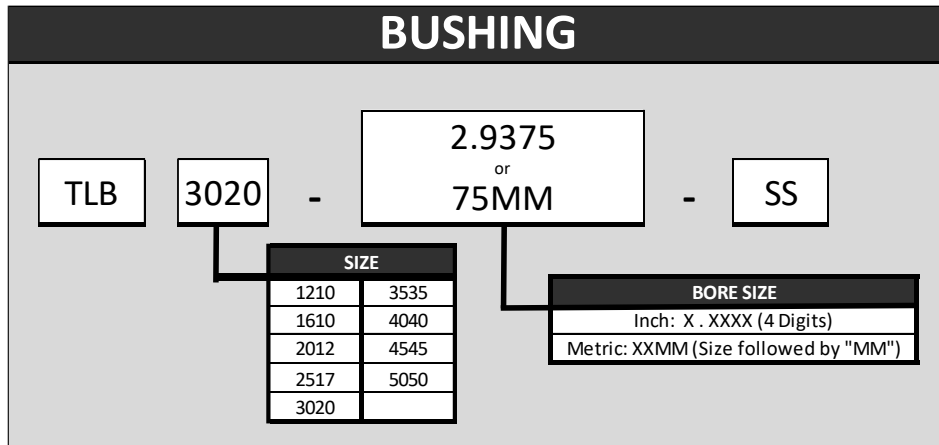
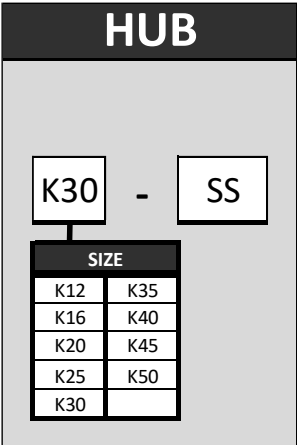

Taper-Lock® is a registered trademark of Reliance Electric



(989)358-6149

www.pcimfg.com

ACCESSORIES

Stainless Steel Compression Hubs & Bushings

Key Sizes – XT® Bushings



Imperial Sized Product (inches)					
	Bore Range		Keyseat Size		Key Stock Size
			Bushings	Axle	
	min	max			F: Full S: Shallow N: None
XT15	5/8	7/8	3/16 X 3/32	3/16 X 3/32	3/16 X 3/16
	15/16	1-1/4	1/4 X 1/8	1/4 X 1/8	1/4 X 1/4
	1-5/16	1-3/8	5/16 X 5/32	5/16 X 5/32	5/16 X 5/16
	1-7/16	1-1/2	3/8 X 1/8	3/8 X 3/16	3/8 X 5/16
XT20	3/4	7/8	3/16 X 3/32	3/16 X 3/32	3/16 X 3/16
	15/16	1-1/4	1/4 X 1/8	1/4 X 1/8	1/4 X 1/4
	1-5/16	1-3/8	5/16 X 5/32	5/16 X 5/32	5/16 X 5/16
	1-7/16	1-3/4	3/8 X 3/16	3/8 X 3/16	3/8 X 3/8
	1-13/16	2	1/2 X 3/16	1/2 X 1/4	1/2 X 7/16
XT25	1	1-1/4	1/4 X 1/8	1/4 X 1/8	1/4 X 1/4
	1-5/16	1-3/8	5/16 X 5/32	5/16 X 5/32	5/16 X 5/16
	1-7/16	1-3/4	3/8 X 3/16	3/8 X 3/16	3/8 X 3/8
	1-13/16	2-1/4	1/2 X 1/4	1/2 X 1/4	1/2 X 1/2
	2-5/16	2-1/2	5/8 X 1/8	5/8 X 5/16	5/8 X 7/16
XT30	1-7/16	1-3/4	3/8 X 3/16	3/8 X 3/16	3/8 X 3/8
	1-13/16	2-1/4	1/2 X 1/4	1/2 X 1/4	1/2 X 1/2
	2-5/16	2-3/4	5/8 X 5/16	5/8 X 5/16	5/8 X 5/8
	2-13/16	3	3/4 X 3/16	3/4 X 3/8	3/4 X 9/16
XT35	1-15/16	2-1/4	1/2 X 1/4	1/2 X 1/4	1/2 X 1/2
	2-5/16	2-3/4	5/8 X 5/16	5/8 X 5/16	5/8 X 5/8
	2-13/16	3-1/4	3/4 X 3/8	3/4 X 3/8	3/4 X 3/4
	3-5/16	3-3/8	7/8 X 7/16	7/8 X 7/16	7/8 X 7/8
	3-7/16	3-1/2	7/8 X 5/16	7/8 X 7/16	7/8 X 3/4
XT40	2-7/16	2-3/4	5/8 X 5/16	5/8 X 5/16	5/8 X 5/8
	2-13/16	3-1/4	3/4 X 3/8	3/4 X 3/8	3/4 X 3/4
	3-5/16	3-3/4	7/8 X 7/16	7/8 X 7/16	7/8 X 7/8
	3-13/16		1 X 1/2	1 X 1/2	1 X 1
	3-7/8	4	1 X 3/8	1 X 1/2	1 X 7/8
XT45	2-7/16	2-3/4	5/8 X 5/16	5/8 X 5/16	5/8 X 5/8
	2-13/16	3-1/4	3/4 X 3/8	3/4 X 3/8	3/4 X 3/4
	3-5/16	3-3/4	7/8 X 7/16	7/8 X 7/16	7/8 X 7/8
	3-13/16	4-5/16	1 X 1/2	1 X 1/2	1 X 1
	4-3/8	4-1/2	1 X 3/8	1 X 1/2	1 X 7/8
XT50	2-15/16	3-1/4	3/4 X 3/8	3/4 X 3/8	3/4 X 3/4
	3-5/16	3-3/4	7/8 X 7/16	7/8 X 7/16	7/8 X 7/8
	3-13/16	4-1/2	1 X 1/2	1 X 1/2	1 X 1
	4-9/16	5	1-1/4 X 5/8	1-1/4 X 5/8	1-1/4 X 1-1/4

Metric Sized Product (mm)					
	Bore Range		Keyseat Size		Key Stock Size
			Bushings	Axle	
	min	max			F: Full S: Shallow N: None
XT15	20		6 X 2.8	6 X 3.5	6 X 6
	25	30	8 X 3.3	8 X 4	8 X 7
	35		10 X 3.3	10 X 5	10 X 8
XT20	20		6 X 2.8	6 X 3.5	6 X 6
	25	30	8 X 3.3	8 X 4	8 X 7
	35		10 X 3.3	10 X 5	10 X 8
	40		12 X 3.3	12 X 5	12 X 8
	45	50	14 X 3.8	14 X 5.5	14 X 9
XT25	25	30	8 X 3.3	8 X 4	8 X 7
	35		10 X 3.3	10 X 5	10 X 8
	40		12 X 3.3	12 X 5	12 X 8
	45	50	14 X 3.8	14 X 5.5	14 X 9
	55		16 X 4.3	16 X 6	16 X 10
	60	65	18 X 4.4	18 X 7	18 X 11
XT30	35		10 X 3.3	10 X 5	10 X 8
	40		12 X 3.3	12 X 5	12 X 8
	45	50	14 X 3.8	14 X 5.5	14 X 9
	55		16 X 4.3	16 X 6	16 X 10
	60	65	18 X 4.4	18 X 7	18 X 11
	70	75	20 X 4.9	20 X 7.5	20 X 12
XT35	50		14 X 3.8	14 X 5.5	14 X 9
	55		16 X 4.3	16 X 6	16 X 10
	60	65	18 X 4.4	18 X 7	18 X 11
	70	75	20 X 4.9	20 X 7.5	20 X 12
	80	85	22 X 5.4	22 X 9	22 X 14
XT40	90		25 X 5.4	25 X 9	25 X 14
	60	65	18 X 4.4	18 X 7	18 X 11
	70	75	20 X 4.9	20 X 7.5	20 X 12
	80	85	22 X 5.4	22 X 9	22 X 14
	90	95	25 X 5.4	25 X 9	25 X 14
XT45	100		28 X 6.4	28 X 10	28 X 16
	80	85	22 X 5.4	22 X 9	22 X 14
XT50	90	95	25 X 5.4	25 X 9	25 X 14
	100	110	28 X 6.4	28 X 10	28 X 16
	115	125	32 X 7.4	32 X 11	32 X 18

ACCESSORIES

Stainless Steel Compression Hubs & Bushings Key Sizes – HE Bushings



Imperial Sized Product (inches)					
	Bore Range		Keyseat Size		Key Stock Size
			Bushings	Axle	F: Full S: Shallow N: None
	min	max			
HE25	1	1-1/4	1/4 X 1/8	1/4 X 1/8	1/4 X 1/4
	1-5/16	1-3/8	5/16 X 5/32	5/16 X 5/32	5/16 X 5/16
	1-7/16	1-3/4	3/8 X 3/16	3/8 X 3/16	3/8 X 3/8
	1-13/16	2-1/4	1/2 X 1/4	1/2 X 1/4	1/2 X 1/2
	2-5/16	2-1/2	5/8 X 3/16	5/8 X 5/16	5/8 X 1/2
HE30	1-7/16	1-3/4	3/8 X 3/16	3/8 X 3/16	3/8 X 3/8
	1-13/16	2-1/4	1/2 X 1/4	1/2 X 1/4	1/2 X 1/2
	2-5/16	2-3/4	5/8 X 5/16	5/8 X 5/16	5/8 X 5/8
HE35	2-13/16	3	3/4 X 1/8	3/4 X 3/8	3/4 X 1/2
	1-15/16	2-1/4	1/2 X 1/4	1/2 X 1/4	1/2 X 1/2
	2-5/16	2-3/4	5/8 X 5/16	5/8 X 5/16	5/8 X 5/8
	2-13/16	3-1/4	3/4 X 3/8	3/4 X 3/8	3/4 X 3/4
	3-5/16	3-5/16	7/8 X 7/16	7/8 X 7/16	7/8 X 7/8
HE40	3-3/8	3-1/2	7/8 X 3/16	7/8 X 7/16	7/8 X 5/8
	2-7/16	2-3/4	5/8 X 5/16	5/8 X 5/16	5/8 X 5/8
	2-13/16	3-1/4	3/4 X 3/8	3/4 X 3/8	3/4 X 3/4
	3-5/16	3-3/4	7/8 X 7/16	7/8 X 7/16	7/8 X 7/8
	3-13/16		1 X 1/2	1 X 1/2	1 X 1
HE45	3-7/8	4	1 X 1/4	1 X 1/2	1 X 3/4
	2-7/16	2-3/4	5/8 X 5/16	5/8 X 5/16	5/8 X 5/8
	2-13/16	3-1/4	3/4 X 3/8	3/4 X 3/8	3/4 X 3/4
	3-5/16	3-3/4	7/8 X 7/16	7/8 X 7/16	7/8 X 7/8
	3-13/16	4-1/8	1 X 1/2	1 X 1/2	1 X 1
HE50	4-3/16	4-1/2	1 X 1/4	1 X 1/2	1 X 3/4
	2-15/16	3-1/4	3/4 X 3/8	3/4 X 3/8	3/4 X 3/4
	3-5/16	3-3/4	7/8 X 7/16	7/8 X 7/16	7/8 X 7/8
	3-13/16	4-1/2	1 X 1/2	1 X 1/2	1 X 1
	4-9/16	4-3/4	1-1/4 X 5/8	1-1/4 X 5/8	1-1/4 X 1-1/4
	4-13/16	5	1-1/4 X 1/4	1-1/4 X 5/8	1-1/4 X 7/8

Metric Sized Product (mm)					
	Bore Range		Keyseat Size		Key Stock Size
			Bushings	Axle	
	min	max			
HE25	25	30	8 X 3.3	8 X 4	8 X 7
	35		10 X 3.3	10 X 5	10 X 8
	40		12 X 3.3	12 X 5	12 X 8
	45	50	14 X 3.8	14 X 5.5	14 X 9
	55		16 X 4.3	16 X 6	16 X 10
HE30	60	65	18 X 4.4	18 X 7	18 X 11
	35		10 X 3.3	10 X 5	10 X 8
	40		12 X 3.3	12 X 5	12 X 8
	45	50	14 X 3.8	14 X 5.5	14 X 9
	55		16 X 4.3	16 X 6	16 X 10
HE35	60	65	18 X 4.4	18 X 7	18 X 11
	70	75	20 X 4.9	20 X 7.5	20 X 12
	50		14 X 3.8	14 X 5.5	14 X 9
	55		16 X 4.3	16 X 6	16 X 10
	60	65	18 X 4.4	18 X 7	18 X 11
HE40	70	75	20 X 4.9	20 X 7.5	20 X 12
	80	85	22 X 5.4	22 X 9	22 X 14
	90		25 X 5.4	25 X 9	25 X 14
	60	65	18 X 4.4	18 X 7	18 X 11
	70	75	20 X 4.9	20 X 7.5	20 X 12
HE45	80	85	22 X 5.4	22 X 9	22 X 14
	90	95	25 X 5.4	25 X 9	25 X 14
	100		28 X 6.4	28 X 10	28 X 16
	80	85	22 X 5.4	22 X 9	22 X 14
	90	95	25 X 5.4	25 X 9	25 X 14
HE50	100	110	28 X 6.4	28 X 10	28 X 16
	115	125	32 X 7.4	32 X 11	32 X 18
	80	85	22 X 5.4	22 X 9	22 X 14

ACCESSORIES

Stainless Steel Compression Hubs & Bushings

Key Sizes – QD® Bushings



Imperial Sized Product (inches)					
	Bore Range		Keyseat Size		Key Stock Size
			Bushings	Axle	F: Full S: Shallow N: None
	min	max			
JA	1/2	9/16	1/8 X 1/16	1/8 X 1/16	1/8 X 1/8
	5/8	7/8	3/16 X 3/32	3/16 X 3/32	3/16 X 3/16
	15/16	1	1/4 X 1/8	1/4 X 1/8	1/4 X 1/4
	1-1/16	1-3/16	1/4 X 1/16	1/4 X 1/8	1/4 X 3/16
	1-1/4		-	-	-
SH	5/8	7/8	3/16 X 3/32	3/16 X 3/32	3/16 X 3/16
	15/16	1-1/4	1/4 X 1/8	1/4 X 1/8	1/4 X 1/4
	1-5/16	1-3/8	5/16 X 5/32	5/16 X 5/32	5/16 X 5/16
	1-7/16	1-5/8	3/8 X 1/16	3/8 X 3/16	3/8 X 1/4
	1-11/16		-	-	-
SDS	3/4	7/8	3/16 X 3/32	3/16 X 3/32	3/16 X 3/16
	15/16	1-1/4	1/4 X 1/8	1/4 X 1/8	1/4 X 1/4
	1-5/16	1-3/8	5/16 X 5/32	5/16 X 5/32	5/16 X 5/16
	1-7/16	1-5/8	3/8 X 3/16	3/8 X 3/16	3/8 X 3/8
	1-11/16	1-3/4	3/8 X 1/8	3/8 X 3/16	3/8 X 5/16
	1-13/16	1-15/16	1/2 X 1/16	1/2 X 1/4	1/2 X 5/16
	2		-	-	-
SK	1	1-1/4	1/4 X 1/8	1/4 X 1/8	1/4 X 1/4
	1-5/16	1-3/8	5/16 X 5/32	5/16 X 5/32	5/16 X 5/16
	1-7/16	1-3/4	3/8 X 3/16	3/8 X 3/16	3/8 X 3/8
	1-13/16	2-1/8	1/2 X 1/4	1/2 X 1/4	1/2 X 1/2
	2-3/16	2-1/4	1/2 X 1/8	1/2 X 1/4	1/2 X 3/8
	2-5/16	2-1/2	5/8 X 1/16	5/8 X 5/16	5/8 X 3/8
	2-5/8		-	-	-
SF	1	1-1/4	1/4 X 1/8	1/4 X 1/8	1/4 X 1/4
	1-5/16	1-3/8	5/16 X 5/32	5/16 X 5/32	5/16 X 5/16
	1-7/16	1-3/4	3/8 X 3/16	3/8 X 3/16	3/8 X 3/8
	1-13/16	2-1/4	1/2 X 1/4	1/2 X 1/4	1/2 X 1/2
	2-5/16		5/8 X 5/16	5/8 X 5/16	5/8 X 5/8
	2-3/8	2-1/2	5/8 X 3/16	5/8 X 5/16	5/8 X 1/2
	2-9/16	2-3/4	5/8 X 1/16	5/8 X 5/16	5/8 X 3/8
	2-13/16		3/4 X 1/8	3/4 X 3/8	3/4 X 1/2
	2-7/8	2-15/16	3/4 X 1/32	3/4 X 3/8	3/4 X 13/32
E	1-7/16	1-3/4	3/8 X 3/16	3/8 X 3/16	3/8 X 3/8
	1-13/16	2-1/4	1/2 X 1/4	1/2 X 1/4	1/2 X 1/2
	2-5/16	2-3/4	5/8 X 5/16	5/8 X 5/16	5/8 X 5/8
	2-13/16	2-7/8	3/4 X 3/8	3/4 X 3/8	3/4 X 3/4
	2-15/16	3-1/4	3/4 X 1/8	3/4 X 3/8	3/4 X 1/2
	3-5/16		7/8 X 1/8	7/8 X 7/16	7/8 X 9/16
	3-3/8	3-1/2	7/8 X 1/16	7/8 X 7/16	7/8 X 1/2
F	1-15/16	2-1/4	1/2 X 1/4	1/2 X 1/4	1/2 X 1/2
	2-5/16	2-3/4	5/8 X 5/16	5/8 X 5/16	5/8 X 5/8
	2-13/16	3-1/4	3/4 X 3/8	3/4 X 3/8	3/4 X 3/4
	3-5/16	3-3/4	7/8 X 3/16	7/8 X 7/16	7/8 X 5/8
	3-7/8	3-15/16	1 X 1/8	1 X 1/2	1 X 5/8
4		-	-	-	
JS	2-15/16	3-1/4	3/4 X 3/8	3/4 X 3/8	3/4 X 3/4
	3-5/16	3-3/4	7/8 X 7/16	7/8 X 7/16	7/8 X 7/8
	3-13/16		1 X 1/2	1 X 1/2	1 X 1
	3-7/8	4	1 X 1/4	1 X 1/2	1 X 3/4
	4-1/16	4-1/2	1 X 1/8	1 X 1/2	1 X 5/8
MS	2-15/16	3-1/4	3/4 X 3/8	3/4 X 3/8	3/4 X 3/4
	3-5/16	3-3/4	7/8 X 7/16	7/8 X 7/16	7/8 X 7/8
	3-13/16	4-1/2	1 X 1/2	1 X 1/2	1 X 1
	4-9/16	4-3/4	1-1/4 X 5/8	1-1/4 X 5/8	1-1/4 X 1-1/4
	4-13/16	5-1/4	1-1/4 X 3/8	1-1/4 X 5/8	1-1/4 X 1
5-5/16	5-1/2	1-1/4 X 1/4	1-1/4 X 5/8	1-1/4 X 7/8	

Metric Sized Product (mm)					
	Bore Range		Keyseat Size		Key Stock Size
			Bushings	Axle	
	min	max			
JA	20		6 X 2.8	6 X 3.5	6 X 6
	25		8 X 3.3	8 X 4	8 X 7
SH	25	30	8 X 3.3	8 X 4	8 X 7
	35		10 X 3.3	10 X 5	10 X 8
SDS	25	30	8 X 3.3	8 X 4	8 X 7
	35		10 X 3.3	10 X 5	10 X 8
	40		12 X 3.3	12 X 5	12 X 8
SK	25	30	8 X 3.3	8 X 4	8 X 7
	35		10 X 3.3	10 X 5	10 X 8
	40		12 X 3.3	12 X 5	12 X 8
	45	50	14 X 3.8	14 X 5.5	14 X 9
	55		16 X 4.3	16 X 6	16 X 10
SF	30		8 X 3.3	8 X 4	8 X 7
	35		10 X 3.3	10 X 5	10 X 8
	40		12 X 3.3	12 X 5	12 X 8
	45	50	14 X 3.8	14 X 5.5	14 X 9
	55		16 X 4.3	16 X 6	16 X 10
	60		18 X 4.4	18 X 7	18 X 11
E	35		10 X 3.3	10 X 5	10 X 8
	40		12 X 3.3	12 X 5	12 X 8
	45	50	14 X 3.8	14 X 5.5	14 X 9
	55		16 X 4.3	16 X 6	16 X 10
	60	65	18 X 4.4	18 X 7	18 X 11
	70	75	20 X 4.9	20 X 7.5	20 X 12
F	45	50	14 X 3.8	14 X 5.5	14 X 9
	55		16 X 4.3	16 X 6	16 X 10
	60	65	18 X 4.4	18 X 7	18 X 11
	70	75	20 X 4.9	20 X 7.5	20 X 12
	80	85	22 X 5.4	22 X 9	22 X 14
	90		25 X 5.4	25 X 9	25 X 14
JS	60	65	18 X 4.4	18 X 7	18 X 11
	70	75	20 X 4.9	20 X 7.5	20 X 12
	80	85	22 X 5.4	22 X 9	22 X 14
	90	95	25 X 5.4	25 X 9	25 X 14
MS	100	110	28 X 6.4	28 X 10	28 X 16
	80	85	22 X 5.4	22 X 9	22 X 14
	90	95	25 X 5.4	25 X 9	25 X 14
	100	110	28 X 6.4	28 X 10	28 X 16
	115	120	32 X 7.4	32 X 11	32 X 18

ACCESSORIES

Stainless Steel Compression Hubs & Bushings Key Sizes – Taper-Lock® Bushings



Imperial Sized Product (inches)					
	Bore Range		Keyseat Size		Key Stock Size
			Bushings	Axle	F: Full S: Shallow N: None
	min	max			
1210	1/2	9/16	1/8 X 1/16	1/8 X 1/16	1/8 X 1/8
	5/8	7/8	3/16 X 3/32	3/16 X 3/32	3/16 X 3/16
	15/16	1-1/4	1/4 X 1/8	1/4 X 1/8	1/4 X 1/4
1610	1/2	9/16	1/8 X 1-1/16	1/8 X 1-1/16	1/8 X 1/8
	5/8	7/8	3/16 X 3/32	3/16 X 3/32	3/16 X 3/16
	15/16	1-1/4	1/4 X 1/8	1/4 X 1/8	1/4 X 1/4
	1-5/16	1-3/8	5/16 X 5/32	5/16 X 5/32	5/16 X 5/16
	1-7/16	1-1/2	3/8 X 3/16	3/8 X 3/16	3/8 X 3/8
	1-9/16	1-11/16	3/8 X 1/8	3/8 X 3/16	3/8 X 5/16
2012	3/4	7/8	3/16 X 3/32	3/16 X 3/32	3/16 X 3/16
	15/16	1-1/4	1/4 X 1/8	1/4 X 1/8	1/4 X 1/4
	1-5/16	1-3/8	5/16 X 5/32	5/16 X 5/32	5/16 X 5/16
	1-7/16	1-3/4	3/8 X 3/16	3/8 X 3/16	3/8 X 3/8
	1-13/16	1-7/8	1/2 X 1/4	1/2 X 1/4	1/2 X 1/2
	1-15/16	2	1/2 X 3/16	1/2 X 1/4	1/2 X 7/16
2517	1	1-1/4	1/4 X 1/8	1/4 X 1/8	1/4 X 1/4
	1-5/16	1-3/8	5/16 X 5/32	5/16 X 5/32	5/16 X 5/16
	1-7/16	1-3/4	3/8 X 3/16	3/8 X 3/16	3/8 X 3/8
	1-13/16	2-1/4	1/2 X 1/4	1/2 X 1/4	1/2 X 1/2
	2-5/16	2-1/2	5/8 X 3/16	5/8 X 5/16	5/8 X 1/2
3020	1-7/16	1-3/4	3/8 X 3/16	3/8 X 3/16	3/8 X 3/8
	1-13/16	2-1/4	1/2 X 1/4	1/2 X 1/4	1/2 X 1/2
	2-5/16	2-3/4	5/8 X 5/16	5/8 X 5/16	5/8 X 5/8
	2-13/16	3	3/4 X 1/4	3/4 X 3/8	3/4 X 5/8
3535	1-15/16	2-1/4	1/2 X 1/4	1/2 X 1/4	1/2 X 1/2
	2-5/16	2-3/4	5/8 X 5/16	5/8 X 5/16	5/8 X 5/8
	2-13/16	3-1/4	3/4 X 3/8	3/4 X 3/8	3/4 X 3/4
	3-5/16		7/8 X 1/8	7/8 X 7/16	7/8 X 9/16
4040	3-3/8	3-1/2	7/8 X 3/16	7/8 X 7/16	7/8 X 5/8
	2-7/16	2-3/4	5/8 X 5/16	5/8 X 5/16	5/8 X 5/8
	2-13/16	3-1/4	3/4 X 3/8	3/4 X 3/8	3/4 X 3/4
	3-5/16	3-3/4	7/8 X 7/16	7/8 X 7/16	7/8 X 7/8
4545	3-13/16	4	1 X 1/4	1 X 1/2	1 X 3/4
	3-7/16	3-3/4	7/8 X 7/16	7/8 X 7/16	7/8 X 7/8
	3-13/16	4-1/4	1 X 1/2	1 X 1/2	1 X 1
5050	4-5/16	4-1/2	1 X 1/4	1 X 1/2	1 X 3/4
	3-5/8	4-1/2	1 X 1/2	1 X 1/2	1 X 1
	4-9/16	5	1-1/4 X 1/4	1-1/4 X 5/8	1-1/4 X 7/8

Metric Sized Product (mm)					
	Bore Range		Keyseat Size		Key Stock Size
			Bushings	Axle	
	min	max			
1210	20		6 X 2.8	6 X 3.5	6 X 6
	25	30	8 X 3.3	8 X 4	8 X 7
1610	20		6 X 2.8	6 X 3.5	6 X 6
	25	30	8 X 3.3	8 X 4	8 X 7
	35		10 X 3.3	10 X 5	10 X 8
	40		12 X 3.3	12 X 5	12 X 8
2012	25	30	8 X 3.3	8 X 4	8 X 7
	35		10 X 3.3	10 X 5	10 X 8
	40		12 X 3.3	12 X 5	12 X 8
	45		14 X 3.8	14 X 5.5	14 X 9
2517	25	30	8 X 3.3	8 X 4	8 X 7
	35		10 X 3.3	10 X 5	10 X 8
	40		12 X 3.3	12 X 5	12 X 8
	45	50	14 X 3.8	14 X 5.5	14 X 9
	55		16 X 4.3	16 X 6	16 X 10
	60	65	18 X 4.4	18 X 7	18 X 11
3020	50		14 X 3.8	14 X 5.5	14 X 9
	55		16 X 4.3	16 X 6	16 X 10
	60	65	18 X 4.4	18 X 7	18 X 11
	70	75	20 X 4.9	20 X 7.5	20 X 12
	70		20 X 4.9	20 X 7.5	20 X 12
3535	50		14 X 3.8	14 X 5.5	14 X 9
	55		16 X 4.3	16 X 6	16 X 10
	60	65	18 X 4.4	18 X 7	18 X 11
	70	75	20 X 4.9	20 X 7.5	20 X 12
	80	85	22 X 5.4	22 X 9	22 X 14
	90		25 X 5.4	25 X 9	25 X 14
4040	60	65	18 X 4.4	18 X 7	18 X 11
	70	75	20 X 4.9	20 X 7.5	20 X 12
	80	85	22 X 5.4	22 X 9	22 X 14
	90	95	25 X 5.4	25 X 9	25 X 14
	100		28 X 6.4	28 X 10	28 X 16
4545	80	85	22 X 5.4	22 X 9	22 X 14
	90	95	25 X 5.4	25 X 9	25 X 14
	100	110	28 X 6.4	28 X 10	28 X 16
	115		32 X 7.4	32 X 11	32 X 18
5050	80	85	22 X 5.4	22 X 9	22 X 14
	90	95	25 X 5.4	25 X 9	25 X 14
	100	110	28 X 6.4	28 X 10	28 X 16
	115	125	32 X 7.4	32 X 11	32 X 18

HUB SELECTION

When choosing a hub and bushing system, it is important to understand the different design features and the effects they have on conveyor pulley applications. Consider a design that minimizes end disk pre-stressing, grips the shaft firmly, is easily removed, and is not adversely affected by the bending moments on the pulley shaft.

XT® HUBS AND BUSHINGS

The XT® Hub and Bushing system was specifically designed for use in conveyor pulleys with two hubs. The XT design has a steep taper angle, 2" taper per foot, which minimizes end disk deflection or pre-stressing that occurs when bushings are installed. The reduction in end disk pre-stressing reduces the likelihood of end disk fatigue. The steep taper angle will reduce the clamping pressure on the shaft, but the XT design compensates by increasing the number and size of the bolts used to install the bushing. The taper angle of the XT design is self-locking, which alleviates bolt-breakage experienced on bushings with a taper angle greater than 2" taper per foot. The holes used to install and remove the bushing are spaced equally around the bushing split and keyway. Upon installation, this balances the load required at each bolt location, which provides consistent contact pressure on the shaft. During removal, the equally spaced jackscrews eliminate the chance of bushing breakage. The steep taper angle requires little force to remove the bushing, further reducing the chance of

	XT® STYLE DRUM PULLEY						
	A	B	C	D	E	F	G
XT15	0.750	1.125	0.437	0.594	1.437	0.625	1.250
XT20	0.625	1.406	0.844	0.422	1.469	0.812	1.219
XT25	0.500	1.875	1.500	0.266	1.562	1.125	1.250
XT30	0.625	2.062	1.156	0.344	1.812	1.250	1.437
XT35	0.625	2.469	1.437	0.312	2.031	1.500	1.594
XT40	0.937	2.812	1.437	0.578	2.500	1.750	2.000
XT45	0.937	3.312	1.719	0.547	2.750	2.125	2.125
XT50	0.937	3.750	2.031	0.469	2.937	2.500	2.187
XT60	0.937	4.125	2.125	0.391	3.125	2.750	2.313
XT70	1.125	4.687	2.500	0.516	3.625	3.125	2.688
XT80	1.125	5.125	3.062	0.437	3.812	3.437	2.812
XT100	1.125	6.187	3.062	0.437	4.312	4.125	3.187
XT120	1.125	7.062	3.062	0.437	4.687	4.812	3.375

	XT® STYLE WING PULLEY						
	A	B	C	D	E	F	G
XT15	1.562	1.125	-	1.313	2.250	0.625	2.063
XT20	0.750	1.406	0.875	0.438	1.594	0.813	1.344
XT25	1.187	1.875	1.000	0.813	2.250	1.125	1.938
XT30	1.062	2.062	0.750	0.625	2.249	1.250	1.874
XT35	1.812	2.469	0.250	1.313	2.219	1.500	2.781
XT40	1.687	2.812	0.687	1.125	3.249	1.750	2.749
XT45	1.437	3.312	1.250	0.813	3.249	2.125	2.624
XT50	2.000	3.750	1.000	1.250	4.000	2.500	3.250
XT60	0.937	4.125	2.125	0.063	3.125	2.750	3.313
XT70	1.125	4.687	2.500	0.250	3.750	3.125	2.813
XT80	1.125	5.125	3.062	0.125	3.938	3.438	2.938
XT100	1.125	6.187	3.062	0.125	4.438	4.125	3.313
XT120	1.125	7.062	3.062	0.125	4.813	4.813	3.500

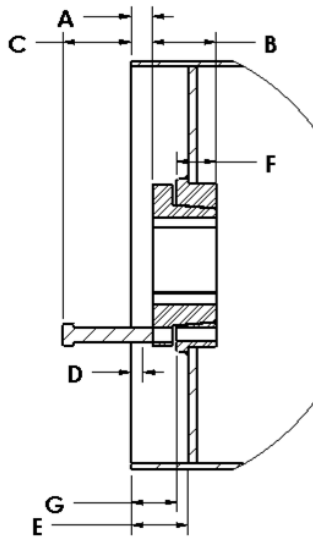

XT DRUM PULLEY

*C: Space required to remove bushing using jackscrews with short hex key or open end wrench.

HUB SIZING

To select a hub size, choose the smallest hub that will allow the shaft size determined per ANSI/CEMA B105.1-1992. Torsional loading and shallow keyways may also affect hub sizing.

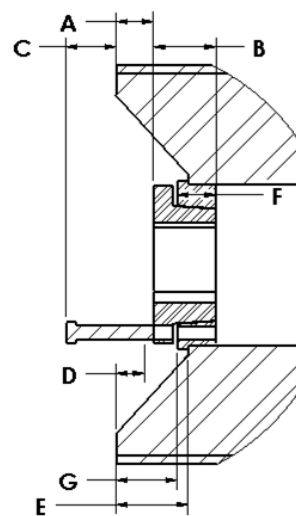

XT WING PULLEY

ACCESSORIES

HE Hub Selection



HUB SELECTION

When choosing a hub and bushing system, it is important to understand the different design features and the effects they have on conveyor pulley applications. Consider a design that minimizes end disk pre-stressing, grips the shaft firmly, is easily removed, and is not adversely affected by the bending moments on the pulley shaft.

HE HUBS AND BUSHINGS

The HE Hub and Bushing system was specifically designed for use in conveyor pulleys with two hubs. The HE design has a very steep taper angle, 3" taper per foot, which minimizes end disk deflection or pre-stressing that occurs when bushings are installed. The reduction in end disk pre-stressing reduces the likelihood of end disk fatigue. The extra steep taper angle is on the edge of being self-locking and increases the likelihood of bolt breakage. Because of this, grade 8 bolts are standard on PCI's HE bushings, and the number of bolts increases from 4 to 6 on HE45 and larger hubs. The holes used to install and remove the bushing are spaced equally around the bushing split and keyway. Upon installation, this balances the load required at each bolt location, which provides consistent contact pressure on the shaft. During removal, the equally spaced jackscrews eliminate the chance of bushing breakage. The steep taper angle requires little force to remove the bushing, further reducing the chance of bushing breakage.

	HE STYLE DRUM PULLEY						
	A	B	C	D	E	F	G
HE25	0.593	1.805	1.861	0.325	1.818	1.140	1.500
HE30	0.658	2.200	2.147	0.294	2.130	1.265	1.750
HE35	0.719	2.780	2.594	0.344	2.380	1.515	1.875
HE40	0.844	2.925	2.373	0.441	2.630	1.765	2.125
HE45	0.903	3.200	3.182	0.500	3.068	2.140	2.438
HE50	0.937	3.700	3.921	0.454	3.475	2.515	2.750
HE60	0.937	3.940	4.376	0.374	3.755	2.765	3.000

	HE STYLE WING PULLEY						
	A	B	C	D	E	F	G
HE25	1.093	1.805	2.361	0.825	2.318	1.140	2.000
HE30	1.033	2.200	2.522	0.669	2.505	1.265	2.125
HE35	1.625	2.780	3.500	1.250	3.286	1.515	2.781
HE40	1.657	2.925	3.186	1.254	3.443	1.765	2.938
HE45	1.465	3.200	3.744	1.062	3.630	2.140	3.000
HE50	1.937	3.700	4.921	1.454	4.475	2.515	3.750
HE60	1.187	3.940	4.626	0.624	4.005	2.765	3.250

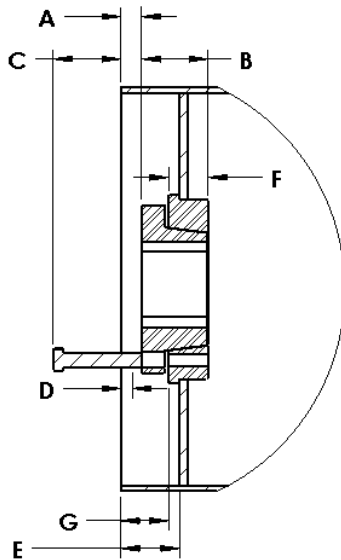

HE DRUM PULLEY

*C: Space required to remove bushing using jackscrews with short hex key or open end wrench.

HUB SIZING

To select a hub size, choose the smallest hub that will allow the shaft size determined per ANSI/CEMA B105.1-1992. Torsional loading and shallow keyways may also affect hub sizing.

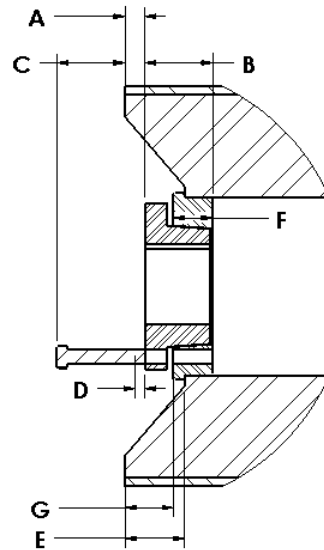

HE WING PULLEY

ACCESSORIES

QD® Hub Selection



HUB SELECTION

When choosing a hub and bushing system, it is important to understand the different design features and the effects they have on conveyor pulley applications. Consider a design that minimizes end disk pre-stressing, grips the shaft firmly, is easily removed, and is not adversely affected by the bending moments on the pulley shaft.

QD® HUBS AND BUSHINGS

The QD® Hub and Bushing system was designed primarily for use in sprockets and sheaves with one hub and has been used widely in conveyor pulleys due to its availability. The QD design has a shallow taper angle, 3/4" taper per foot, causes the end disk to deflect or pre-stress when bushings are installed. bushing, further reducing the chance of bushing breakage.

	QD® STYLE DRUM PULLEY						
	A	B	C	D	E	F	G
JA	0.687	1.000	0.437	0.500	1.500	0.562	1.125
SH	0.750	1.312	0.812	0.500	1.875	0.812	1.375
SDS	0.750	1.312	0.812	0.500	1.812	0.750	1.375
SK	0.812	1.937	1.437	0.500	2.000	1.000	1.563
SF	0.875	2.062	1.375	0.500	2.187	1.000	1.750
E	1.000	2.750	2.062	0.500	2.687	1.125	2.187
F	1.062	3.750	2.937	0.500	3.000	1.250	2.437
JS	1.250	3.375	1.812	0.500	3.125	1.625	2.500
MS	1.250	4.812	2.250	0.500	3.562	2.375	2.812
NS	1.312	6.000	2.750	0.500	4.062	2.375	3.250
PS	1.375	6.500	3.750	0.500	4.250	2.875	3.375
WS	1.562	7.250	4.125	0.500	4.750	3.375	3.813
SS	1.625	8.750	4.187	0.500	5.250	3.875	4.125
ZS	1.562	8.750	4.125	0.500	5.562	4.875	4.312

	QD® STYLE WING PULLEY						
	A	B	C	D	E	F	G
JA	0.562	1.000	0.562	0.375	1.375	0.563	1.000
SH	0.625	1.312	0.937	0.375	1.625	0.813	1.125
SDS	0.625	1.312	0.937	0.375	1.625	0.750	1.188
SK	0.687	1.937	1.562	0.375	2.063	1.000	1.625
SF	0.750	2.062	1.500	0.375	2.250	1.000	1.813
E	0.875	2.750	2.187	0.375	3.000	1.125	2.500
F	0.937	3.750	3.062	0.375	4.000	1.250	3.438
JS	1.000	3.375	1.937	0.375	3.375	1.625	2.750
MS	1.125	4.812	2.375	0.375	4.133	2.375	3.563
NS	1.187	6.000	2.875	0.313	5.625	2.375	4.813
PS	1.250	6.500	3.875	0.250	5.750	2.875	4.875
WS	1.437	7.250	4.250	0.313	6.250	3.375	5.313
SS	1.500	8.750	4.312	0.250	7.500	3.875	6.375
ZS	1.437	8.750	4.250	0.188	6.563	4.875	5.313

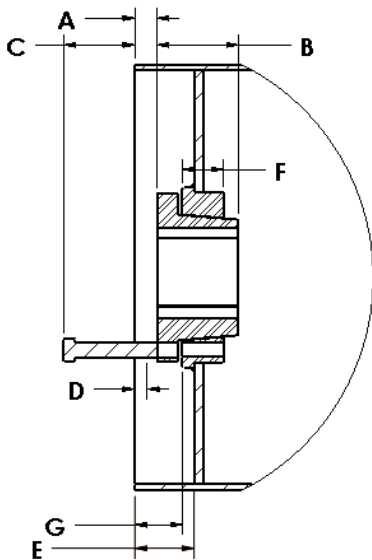

QD DRUM PULLEY

*C: Space required to remove bushing using jackscrews with short hex key or open end wrench.

HUB SIZING

To select a hub size, choose the smallest hub that will allow the shaft size determined per ANSI/CEMA B105.1-1992. Torsional loading and shallow keyways may also affect hub sizing.

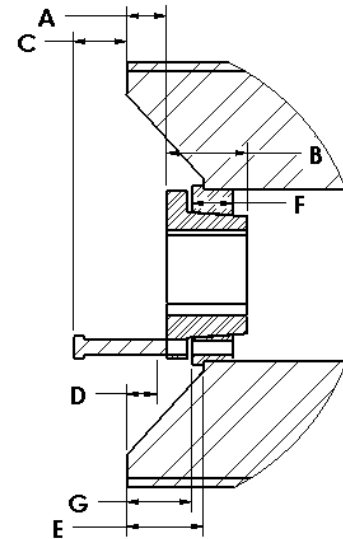

QD WING PULLEY

HUB SELECTION

When choosing a hub and bushing system, it is important to understand the different design features and the effects they have on conveyor pulley applications. Consider a design that minimizes end disk pre-stressing, grips the shaft firmly, is easily removed, and is not adversely affected by the bending moments on the pulley shaft.

TAPER-LOCK® HUBS AND BUSHINGS

The Taper-Lock® Hub and Bushing system was designed primarily for use in sprockets and sheaves with one hub and has been used widely in conveyor pulleys due to its availability. The Taper-Lock® design has a taper angle of 8 degrees or 1-11/16" taper per foot, which minimizes end disk deflection. However, of all hub and bushing systems, it has the lowest ability to grip the shaft. When a Taper-Lock® bushing is installed, it is flush with the outer surface of the hub providing a clean appearance.

TYPE-K TAPERED HUB	TAPERED BUSHING	TAPER-LOCK® STYLE DRUM PULLEY					
		A	B	C	D	E	F
K12	1210	0.750	1.000	3.120	0.750	1.062	0.875
K16	1610	0.750	1.000	3.120	0.750	1.062	0.875
K20	2012	0.750	1.250	0.625	0.750	1.062	1.000
K25	2517	0.750	1.750	0.875	0.750	1.125	1.500
K30	3020	0.750	2.000	1.312	0.750	1.125	1.625
K35	3535	0.750	3.500	1.937	0.750	1.250	1.625
K40	4040	0.750	4.000	2.625	0.750	1.250	2.125
K45	4545	0.750	4.500	3.312	0.750	1.375	2.625
K50	5050	0.750	5.000	4.062	0.750	1.375	2.875
K60	6050	2.000	5.000	2.375	0.906	2.625	2.875
K70	7060	2.000	6.000	2.375	0.906	2.750	3.375
K80	8065	2.000	6.500	2.375	0.906	2.750	3.625
K100	10085	2.000	8.500	3.375	0.687	3.000	4.125
K120	120100	2.000	10.000	3.375	0.687	3.000	5.375

TYPE-K TAPERED HUB	TAPERED BUSHING	TAPER-LOCK® STYLE WING PULLEY					
		A	B	C	D	E	F
K12	1210	1.437	1.000	0.000	1.438	1.875	0.875
K16	1610	1.437	1.000	0.000	1.438	1.875	0.875
K20	2012	1.687	1.250	0.000	1.688	2.250	1.000
K25	2517	1.625	1.750	0.000	1.625	2.243	1.500
K30	3020	1.750	2.000	0.375	1.750	2.500	1.625
K35	3535	2.750	3.500	0.000	2.750	5.125	1.625
K40	4040	2.750	4.000	0.625	2.750	5.125	2.125
K45	4545	2.625	4.500	1.500	2.625	5.125	2.625
K50	5050	3.375	5.000	1.500	3.375	6.125	2.875
K60	6050	3.375	5.000	1.000	3.375	6.125	2.875
K70	7060	3.250	6.000	1.125	3.250	6.625	3.375
K80	8065	3.250	6.500	1.125	3.250	6.875	3.625
K100	10085	4.000	8.500	1.375	4.000	9.375	4.125
K120	120100	4.000	10.000	1.375	4.000	9.625	5.375

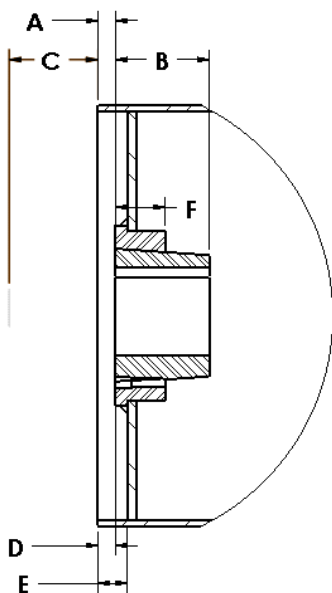

*C: Space required to remove bushing using jackscrews with short hex key or open end wrench.

HUB SIZING

To select a hub size, choose the smallest hub that will allow the shaft size determined per ANSI/CEMA B105.1-1992. Torsional loading and shallow keyways may also affect hub sizing.

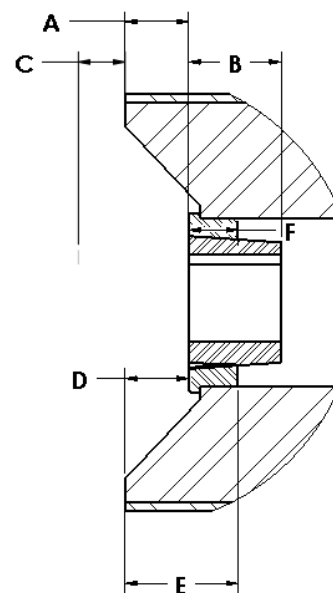

TAPER-LOCK® DRUM PULLEY

TAPER-LOCK® WING PULLEY